

★
T.O. 31R2-4-101-2

**HANDBOOK
SERVICE INSTRUCTIONS**

RADIO RECEIVER

MODEL SP-600-JX-21

(HAMMARLUND)

PUBLISHED UNDER AUTHORITY OF THE SECRETARY OF THE AIR FORCE

Reproduction for non-military use of the information or illustrations contained in this publication is not permitted without specific approval of the issuing service (BuAer or USAF). The policy for use of Classified Publications is established for the Air Force in AFR 205-1 and for the Navy in Navy Regulations, Article 1509.

LIST OF REVISED PAGES ISSUED

INSERT LATEST REVISED PAGES. DESTROY SUPERSEDED PAGES.

NOTE: The portion of the text affected by the current revision is indicated by a vertical line in the outer margins of the page.

*The asterisk indicates pages revised, added or deleted by the current revision.

ADDITIONAL COPIES OF THIS PUBLICATION MAY BE OBTAINED AS FOLLOWS:

USAF

USAF ACTIVITIES.—In accordance with Technical Order No. 00-5-2.

NAVY ACTIVITIES.—Submit request to nearest supply point listed below, using form NavAer-140: NASD, Philadelphia, Pa.; NAS, Alameda, Calif.; NAS, Jacksonville, Fla.; NAS, Norfolk, Va.; NAS, San Diego, Calif.; NAS, Seattle, Wash.; ASD, NSC, Guam.

For listing of available material and details of distribution see Naval Aeronautics Publications Index NavAer 00-500.

TABLE OF CONTENTS

<i>Section</i>	<i>Page</i>
INTRODUCTION	1
I DESCRIPTION AND LEADING PARTICULARS	1
1-1. General	1
1-4. Purpose and Limitations	1
1-10. Leading Particulars	2
1-20. Condensed Factual Data	4
1-33. Operating and Adjustment Controls	7
II TEST EQUIPMENT AND SPECIAL TOOLS	9
2-1. Test Equipment	9
2-3. Special Tools	9
2-5. Cable Fabrication	9
III PREPARATION FOR USE AND RESHIPMENT	11
3-1. Preparation for Use	11
3-7. Preparation for Reshipment or Storage	11
IV THEORY OF OPERATION	13
4-1. General System Operation	13
4-4. Receiving System Block Diagram	13
4-8. Receiver Functional Operation	13
4-22. Simplified Circuit Theory	18
V ORGANIZATIONAL MAINTENANCE	33
5-1. General	33
5-3. Receiver Performance Tests	33
5-6. Trouble Analysis	33
5-11. Minor Repair and Replacement	39
5-16. Removal and Replacement of Subassemblies	39
5-19. Alignment and Adjustment	42
5-23. Preventive Maintenance	43
VI FIELD MAINTENANCE	45
6-1. Trouble Analysis	45
6-7. Removal and Replacement	52
6-14. Receiver Alignment and Adjustment	54
6-17. Receiver Performance Tests	54
6-19. Preventive Maintenance	54
6-22. Overhaul Schedule	60
VII DIAGRAMS	61
7-1. General	61
7-3. Index of Diagrams	61
7-5. Tube-socket Terminal Voltage Diagram	61
7-7. Tube-socket Terminal Resistance Diagram	61
VIII DIFFERENCE DATA SHEETS	65

LIST OF ILLUSTRATIONS

<i>Figure</i>	<i>Page</i>
1-1 Radio Receiver, Model SP-600-JX-21	iv
1-2 Radio Receiver, Front Panel View	2
1-3 Radio Receiver, Rear View	3
1-4 Overall Selectivity Curves at Two Megacycles	6
1-5 Audio and Overall Fidelity Curves	7
2-1 Special Pliers	9
2-2 Antenna Cable	10
2-3 Cathode-follower Cable	10
4-1 Space-diversity Reception of Frequency-shift Signals, System Block Diagram	14
4-2 Radio Receiver, Block Diagram	15
4-3 Radio-frequency Amplifiers, Schematic Diagram	17
4-4 Single- and Double-conversion Circuits, Schematic Diagram	19
4-5 Fixed-frequency and Variable-frequency Oscillators, Schematic Diagram	20
4-6 455-kc Crystal Filter, Simplified Schematic Diagram	22
4-7 445-kc Intermediate-frequency Amplifier Circuits, Schematic Diagram	24
4-8 Beat-frequency Oscillator and Buffer Circuits, Schematic Diagram	26
4-9 Detector, Noise-limiter and A-V-C Circuits, Schematic Diagram	27
4-10 Audio Circuits, Schematic Diagram	29
4-11 Power Supply, Schematic Diagram	30
5-1 Receiver Sensitivity Test Setup	33
5-2 Receiver Cathode-follower Test Setup	37
5-3 Radio Receiver Test-point Location	38
5-4 Radio Receiver, Top View of Chassis	41
5-5 Radio Receiver Alignment Adjustments	42
6-1 Receiver Audio Response Test Setup	49
6-2 Receiver Overall Response Test Setup	53
6-3 Test Setup for Alignment of Receiver I-F Stages	54
6-4 Alternate Test Setup for Alignment of Receiver I-F Stages	59
7-1 Radio Receiver, Schematic Diagram	62
7-2 Tube-socket Terminal Voltage Diagram	63
7-3 Tube-socket Terminal Resistance Diagram	64

LIST OF TABLES

<i>Table</i>	<i>Page</i>
I Tube Complement	4
II Fuse Complement	5
III Tuning Band Ranges	5
IV Image Rejection Ratios	5
V Test Equipment Required for Maintenance	9
VI Special Tools Required for Maintenance	9
VII Power Transformer Tap Voltage Ratings	11
VIII Plug Connector Assemblies Removed from Receiver for Shipment	11
IX Receiver Performance Tests	34
X Power Supply Test-point Data	37
XI Receiver Sections Test-point Data	40
XII Alignment Frequency and Adjustment Designations	43
XIII Inspection Schedule	43
XIV Troubleshooting	45
XV Tube-socket Terminal Voltages	49
XVI Tube-socket Terminal Resistances	51
XVII D-C Resistance of Coils and Windings	52
XVIII Receiver Alignment and Adjustment Procedures	55
XIX Receiver Performance Tests	58
XX Receiver Overhaul Schedule	60

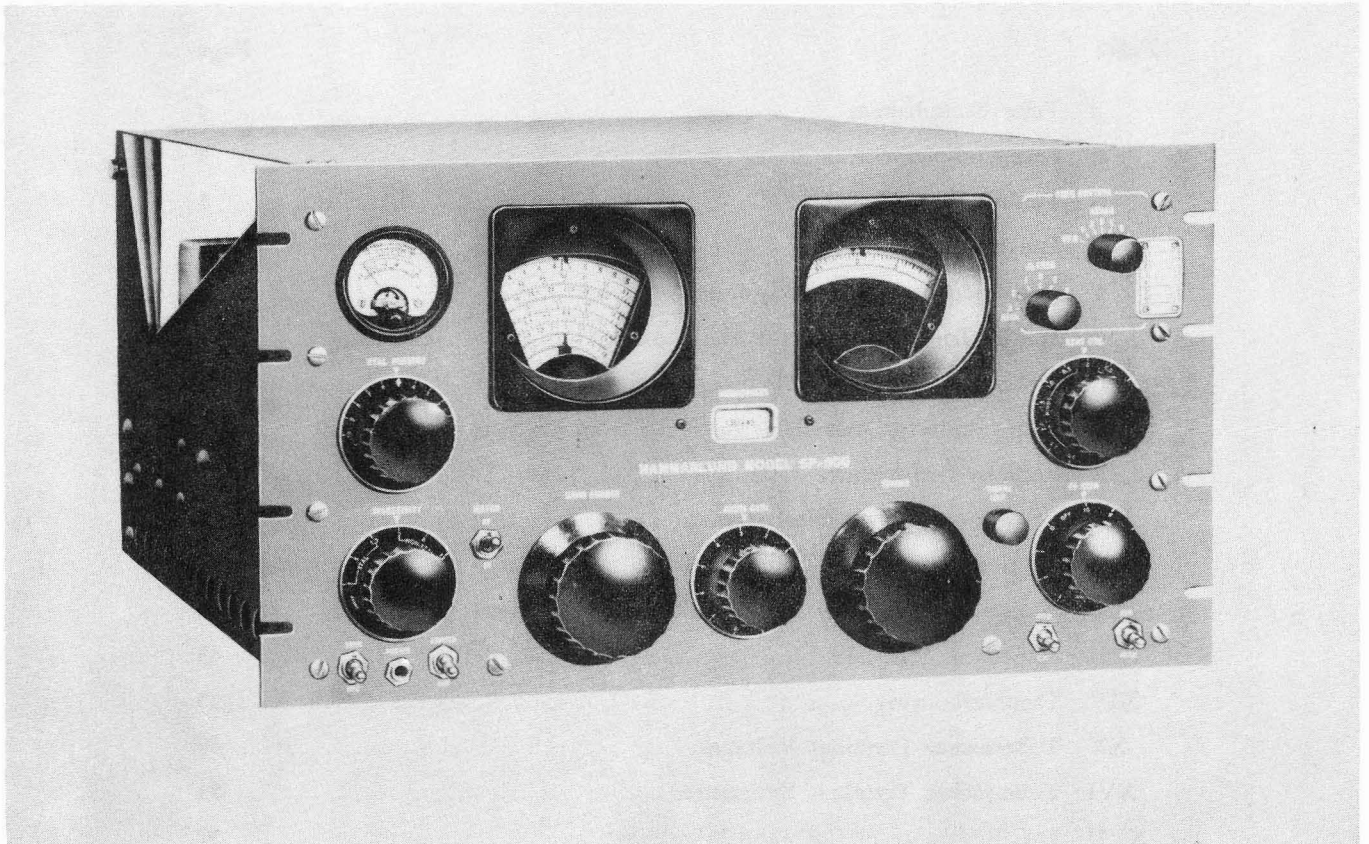

Figure 1-1. Radio Receiver, Model SP-600-JX-21

INTRODUCTION

This handbook has been published to furnish maintenance personnel with descriptive information and maintenance instructions for Radio Receiver, Model SP-600-JX-21, manufactured by the Hammarlund Manufacturing Co., Inc., New York 1, N. Y.

The handbook has been prepared in accordance with Specification MIL-H-6757A(ASG). Abbreviations used are in accordance with Air Force-Navy Aeronautical Bulletin No. 261. Electrical and electronic symbols used in the schematic diagrams conform to Standard JAN-STD-15.

For additional information on the radio receiver, the following publications should be consulted:

<i>Title</i>	<i>Publication No.</i>
Handbook Operation Instructions Radio Receiver, Model SP-600-JX-21	T.O. 31R2-4-101-1
Handbook Overhaul Instructions, Radio Receiver, Model SP-600-JX-21	T.O. 31R2-4-101-3
Illustrated Parts Breakdown, Radio Receiver, Model SP-600-JX-21	T.O. 31R2-4-101-4

SECTION I

DESCRIPTION AND LEADING PARTICULARS

1-1. GENERAL.

1-2. This publication comprises service instructions for Radio Receiver, Model SP-600-JX-21 (figure 1-1), which is manufactured by the Hammarlund Manufacturing Company, Inc., New York 1, N. Y.

1-3. Sections I through VII of this handbook apply to the rack mounted version of Radio Receiver, Model SP-600-JX-21. If additional models become effective, they will be covered in Section VIII by the use of Difference Data Sheets.

1-4. PURPOSE AND LIMITATIONS.

1-5. Radio Receiver, Model SP-600-JX-21, is a multi-band communications receiver designed for the reception of A-M radio telephone, c-w telegraph, and A-M m-c-w telegraph signals in the frequency range of 0.54 mc to 54.0 mc.

1-6. The receiver, designed for mounting in a standard 19-inch relay rack, consists of a chassis and light grey front panel assembly to which are mounted a top cover and a bottom plate. It is intended for use in fixed and/or mobile operations such as those at enclosed base stations, aboard ship, or aboard aircraft, even when such activities are subjected to wide ranges in temperature and humidity. The receiver is treated with fungicidal varnish to condition it for tropical use. Its design and shielding reduce its radiation characteristics to a minimum, thereby complying with shipboard regulations and enabling the receiver to be operated in close proximity to other station equipment in multi-receiver installations. It is suited to two-way operational activities and may be disabled in the presence of a strong local carrier, by means of the "SEND/REC" switch (21, figure 1-2).

1-7. The receiver is of the superheterodyne type. It utilizes six frequency bands for the continuously variable, selective reception of any signal within the frequency range of 0.54 to 54.0 mc. It has provisions for fixed-channel crystal-controlled operation on any of six frequencies within the range of 0.75 mc to 54.0 mc. Incoming signals are converted by the heterodyne process into an intermediate frequency of 455 kc. Single conversion is used for signal frequencies up to 7.4 mc, and double conversion is used for signal frequencies above 7.4 mc.

1-8. Various connectors are provided on the front and rear panels to facilitate use with a variety of signals, such as amplitude-modulated, suppressed carrier, keyed carrier, and frequency-shift types. For the reception of radio telephone or low-speed (manual, telegraph signals, a headset is plugged in the "PHONES" jack (20, figure 1-2) located on the front panel, or a loud speaker is connected to the "AUDIO OUTPUT" terminals (8, figure 1-3) on the rear apron. For high-speed (automatic) telegraph operation, the receiver d-c output developed between the jumpered "DIODE OUTPUT" terminals (2, figure 1-3) and chassis ground, may be used to operate a tape ink recorder, or the receiver a-c output developed at the "AUDIO OUTPUT" terminals may be used to operate a recorder driving unit associated with the tape ink recorder. For the reception of frequency-shift teletype signals, the i-f output developed at the "IF OUTPUT" connector (6, figure 1-3) or the a-f output developed at the "AUDIO OUTPUT" terminals may be used to operate suitable frequency-shift converter equipment. For the reception of keyed-carrier, single or two-tone carrier teletype, the a-f output

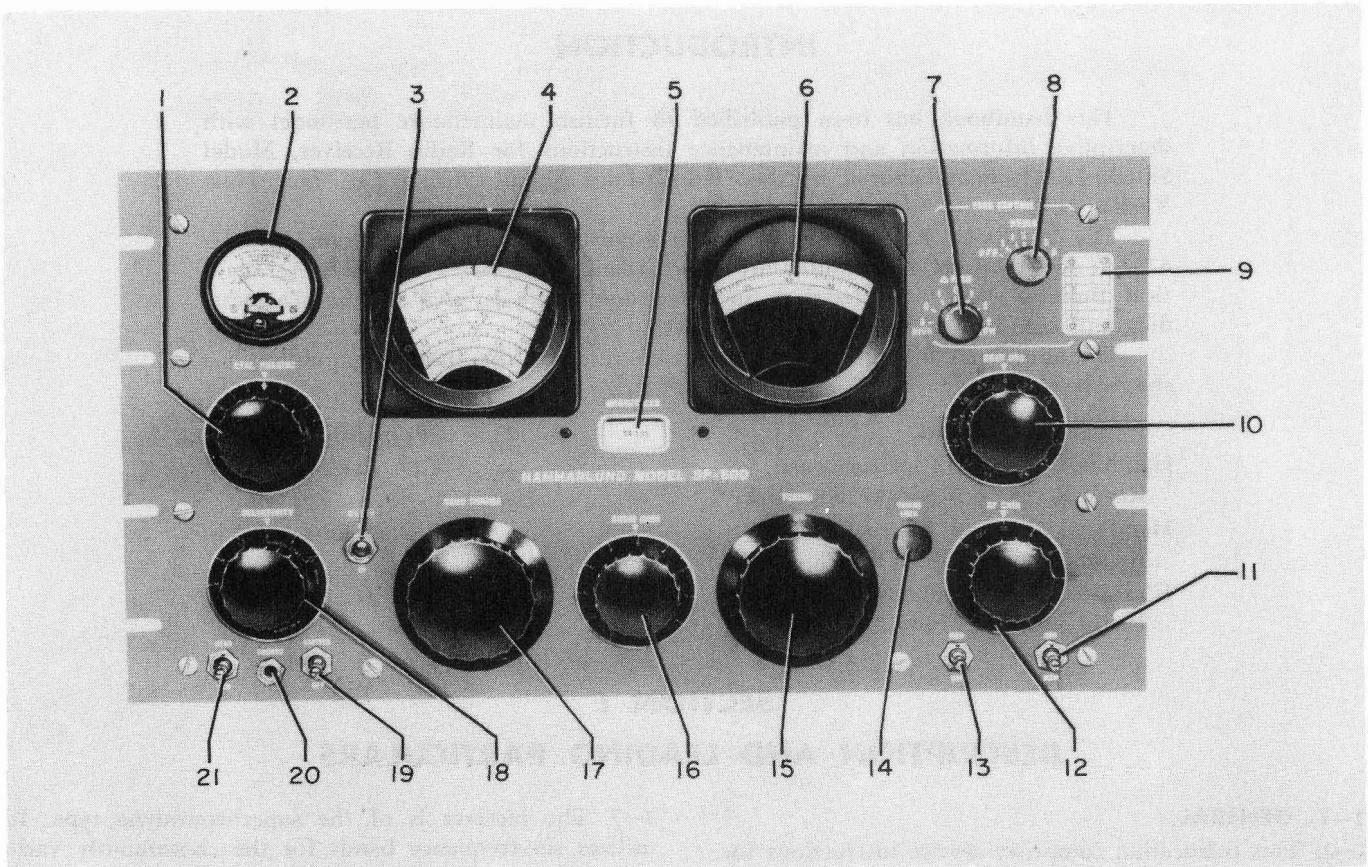

- | | | |
|---------------------------|-----------------------------------|---------------------------|
| 1. "XTAL PHASING" control | 8. "FREQ CONTROL" selector switch | 15. "TUNING" control |
| 2. Tuning meter | 9. Plastic chart | 16. "AUDIO GAIN" control |
| 3. "METER" switch | 10. "BEAT OSC." control | 17. "BAND CHANGE" control |
| 4. Main tuning dial | 11. "AVC/MAN" switch | 18. "SELECTIVITY" switch |
| 5. "MEGACYCLES" window | 12. "RF GAIN" control | 19. "LIMITER/OFF" switch |
| 6. Vernier dial | 13. "MOD/CW" switch | 20. "PHONES" jack |
| 7. "Δ FREQ" control | 14. "TUNING LOCK" switch | 21. "SEND/REC" switch |

Figure 1-2. Radio Receiver, Front Panel View

developed at the "AUDIO OUTPUT" terminals may be used to operate suitable demodulator equipment associated with a teletype-writer.

1-9. The receiver self-contained stabilized power supply is designed to operate from a single phase 50- to 60-cycle, a-c source. The power transformer primary is provided with taps covering a line voltage range from 90 to 270 volts. The receiver is protected against overload by fusing the power transformer primary and secondary plate windings. The primary and secondary fuses used are contained respectively in the "LINE" and "-B" fuse holders (11 and 1, figure 1-3) on the rear apron of the receiver. A duplicate of each of these fuses, comprising the receiver spare fuse complement, is located under the polystyrene "SPARK FUSES" cover (10). The receiver ac power cord (9) can be connected directly to an a-c power source.

1-10. LEADING PARTICULARS.

1-11. The receiver antenna system used is connected to the "ANT" input connector (J1, figure 5-4). The receiver input impedance is designed to match a 95-ohm

transmission line. A straight wire or balanced doublet antenna system is used with the receiver. The receiver rotary turret houses the frequency determining r-f tuner subassemblies that are used for the six frequency bands of the receiver. Each frequency band has an antenna, two identical interstage r-f tuner subassemblies and an oscillator r-f tuner subassembly. The "BAND CHANGE" control (17, figure 1-2) is geared to the rotary turret and is used to select the frequency band desired. It may be turned in either direction and requires a rotation of 360 degrees to position the rotary turret to a different band. An indenting mechanism locks the tuner into position on each band. The band indicator dial visible through the "MEGACYCLES" window (5) indicates the frequency band selected. The "BAND CHANGE" control (17) positions the movable pointer of the main tuning dial (4) to the proper frequency scale on the dial. The main dial outer scale is arbitrarily calibrated, and in conjunction with the vernier dial (6) scale, provides a continuous vernier scale which facilitates extremely accurate station logging and receiver resettability.

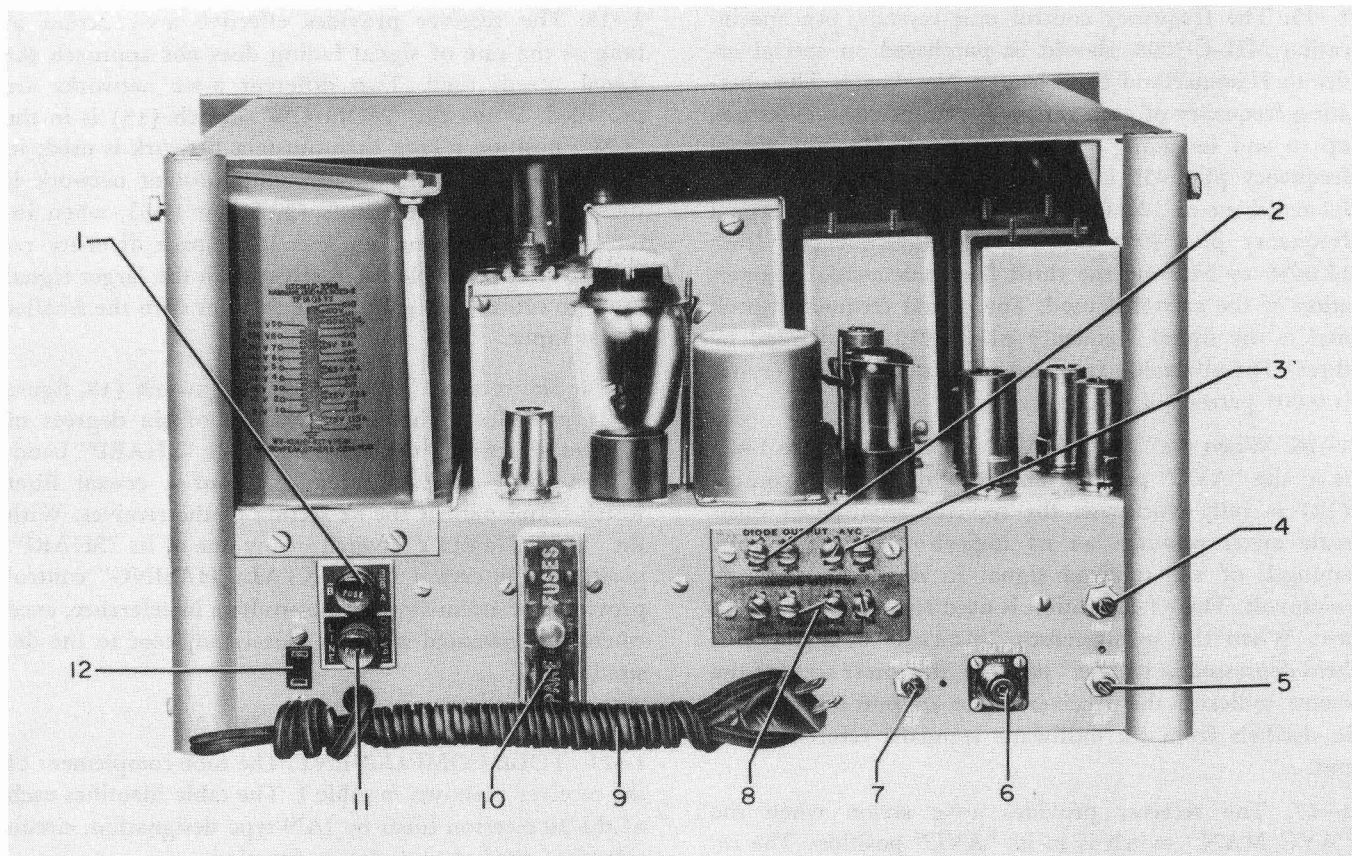

- | | |
|-----------------------------|-----------------------------|
| 1. "-B" fuse | 7. "METER ADJ AF" control |
| 2. "DIODE OUTPUT" terminals | 8. "AUDIO OUTPUT" terminals |
| 3. "AVC" terminals | 9. Power cord |
| 4. "BFO INJ" control | 10. "SPARE FUSES" cover |
| 5. "METER ADJ RF" control | 11. "LINE" fuse |
| 6. "IF OUTPUT" connector | 12. "AC" power outlet |

Figure 1-3. Radio Receiver, Rear View

1-12. The "TUNING" control (15, figure 1-2) is fly-wheel balanced to provide operating ease at high traverse speeds. It controls both the main and vernier dials. An antibacklash gear train maintains the extremely close calibration accuracy and provides for the accurate re-settability of the receiver. The "TUNING LOCK" (14) provides locking action without affecting the frequency setting. The tuning ratio from the tuning control to the main dial is 50 to one and the ratio from the vernier dial to the main dial is six to one.

1-13. The receiver circuitry available for single conversion includes two stages of r-f amplification, a mixer, a heterodyne oscillator, four stages of i-f amplification, a detector and an a-v-c rectifier, a noise limiter and a meter rectifier, a beat-frequency oscillator, a beat-frequency buffer amplifier, an i-f output stage, an a-f amplifier, and an a-f power output stage. The receiver circuitry available for double conversion does not include the initial gate stage of the i-f amplifier used for single conversion, but includes a second mixer and a

second heterodyne crystal-controlled oscillator. The receiver self-contained power supply system includes a full-wave power rectifier and voltage regulator, and a full-wave bias rectifier.

1-14. For fixed-frequency crystal-controlled reception, the variable-frequency first heterodyne oscillator is replaced by a fixed-frequency crystal-controlled oscillator. This is accomplished when the "FREQ CONTROL" selector switch (8, figure 1-2) is switched from its "VFO" to one of its "XTALS" positions. Each of the six "XTALS" positions is associated with a crystal which is suited to the frequency of the operational activity contemplated. The small plastic chart (9) is used to record the applicable signal frequency for each of the crystals. For crystal-controlled reception, the main dial is set to the signal frequency, and tuning is accomplished through use of the " Δ FREQ" control (7). A slight tuning adjustment in the chosen setting of the "TUNING" control (15) is desirable to resonate the r-f section to the signal.

1-15. The frequency control unit crystals, per Specification MIL-C-3098, should be purchased on special order to Hammarlund Specification No. 31473. The operating frequency of each crystal for single-conversion use, up to and including 7.4 mc, is specified as the signal frequency plus 455 kc; and for double-conversion use, from 7.4 mc to 12.0450 mc, it is specified as the signal frequency plus 3955 kc. For signal frequencies from 12.0450 to 54.0 mc the third harmonic mode of operation of the crystal is used. The crystal frequency specified is the signal frequency plus 3.955 mc divided by three. The allowable frequency tolerance of each crystal is 0.005 percent of frequency.

1-16. When the "AVC/MAN" switch (11, figure 1-2) is in the "AVC" position and the "RF GAIN" control (12) is fully clockwise, the receiver front-panel dual-scale meter provides an r-f indication of the relative strength of the received signal in decibels from one microvolt. The r-f indication is used for tuning when on avc. When the spring-return "METER" switch (3) is held depressed in its "AF" position, the lower scale of the meter indicates the receiver audio output power level in decibels from six milliwatts standard reference output.

1-17. The receiver provides a-v-c action when the "AVC/MAN" switch is in its "AVC" position. The receiver gain maintained is dependent on the setting of the "RF GAIN" control. For normal keyed carrier reception, the receiver "BEAT OSC." control (10, figure 1-2) may be set to provide receiver single-tone output at any pitch within the range of plus or minus three kc from zero tone output. For frequency-shift reception, the two-tone receiver output provided is dependent on the setting chosen for the control and on the carrier frequency-shift.

1-18. The receiver provides effective a-v-c action as long as the rate of signal fading does not approach the signal speeds used. Two different a-v-c networks are provided. When the "MOD/CW" switch (13) is in the "CW" position a long time-constant network is used; in the "MOD" position, a short time-constant network is used. The "AVC" terminals (3, figure 1-3), when interconnected between receivers in a space diversity receiving system, enable the receiver with the larger signal input to control the gain of the receiver with the smaller signal input.

1-19. The receiver "SELECTIVITY" switch (18, figure 1-2) provides a choice of any one of six degrees of receiver selectivity, the three narrower "SHARP" bandwidths being realized through use of a crystal filter which forms part of the i-f section of the receiver. With the "SELECTIVITY" switch in any one of its "SHARP" positions, the crystal filter "XTAL PHASING" control provides for attenuation of heterodyne interference, even when the unwanted signal is closely adjacent to the desired signal.

1-20. CONDENSED FACTUAL DATA.

1-21. TUBE COMPLEMENT. The tube complement of the receiver is shown in table I. The table identifies each of the 20 electron tubes by JAN-type designation, circuit reference symbol and circuit function.

1-22. FUSE COMPLEMENT. The fuse complement of the receiver (table II) consists of two fuses and a spare for each. Each fuse is glass-enclosed, indicating, and commercially available. The 3/8-ampere fuse is of the instantaneous type and the 1.6-ampere fuse is of the slow-blow time-delay type. The table identifies each fuse by Bussman Manufacturing Company part number, ampere rating, circuit reference symbol, and type.

TABLE I. TUBE COMPLEMENT

JAN Type	Qty	Function	Reference Symbol
5749/6BA6W	7	Amplifiers: r-f, i-f, b-f-o buffer	V1, V2, V7, V9, V10, V11, V12
6C4	3	Oscillators: variable frequency, 3.5-mc, bfo	V4, V8, V13
6AC7	1	Oscillator, fixed frequency	V3
6BE6	2	Mixers: first, second	V5, V6
5726/6AL5/6097	3	Detector and avc; limiter and meter; bias rectifier	V14A, B; V15A, B; V20
12AU7	1	Cathode follower and first audio	V16
6V6GT	1	Audio power output	V17
5R4GY	1	Rectifier	V19
0A2	1	Voltage regulator	V18

TABLE II. FUSE COMPLEMENT

Bussman Part No.	Qty	Ampere Rating	Type	Reference Symbol
AGC 3/8	2	3/8	Cartridge	F2
MDL 1-6/10 125V, Fusetron	2	1.6	Cartridge	F1

1-23. FREQUENCY RANGE AND STABILITY. The six frequency bands of the receiver provide for continuous reception within the frequency range of 0.54 to 54.0 mc. Subsequent to a 15-minute warmup period, the receiver frequency drift, as a percentage of the signal frequency tuned in, ranges from 0.001 to 0.01 percent. This frequency stability approaches that provided by the receiver for fixed-frequency crystal-controlled reception, within the frequency range of 0.75 mc to 54.0 mc.

1-24. TUNING BAND RANGES. The tunable frequency range of each of the six frequency bands of the receiver is shown in table III. The innermost scale of the main tuning dial is that for the lowest frequency range. The band numeral assigned each band is an arbitrary designation.

1-25. OUTPUT CHARACTERISTICS. The maximum undistorted power output of the receiver is two watts. The receiver audio output terminals and the i-f output connector are designed to match loads of 600 ohms and 70 ohms, respectively. An 8000-ohm headset is recommended for use with the phones jack. When the audio output is 500 milliwatts across a 600-ohm load, the phones output is 15 milliwatts; and with two microvolts receiver signal input, the i-f output to a 70-ohm load is a minimum of 0.6 milliwatt.

1-26. SENSITIVITY. The m-c-w sensitivity of the receiver to any signal frequency within its tuning range is two microvolts or better, for a signal-plus-noise to noise power ratio of ten to one at the receiver audio output terminals. Similarly, the c-w sensitivity of the receiver is 0.75 microvolt, or better.

TABLE III. TUNING BAND RANGES

Band No.	Frequency Range
1	0.54 to 1.35 mc
2	1.35 to 3.45 mc
3	3.45 to 7.40 mc
4	7.40 to 14.80 mc
5	14.80 to 29.70 mc
6	29.70 to 54.00 mc

1-27. SELECTIVITY. The receiver selectivity or band-pass characteristics provided for each of the six positions of the selectivity switch are shown in figure 1-4.

1-28. FIDELITY. The audio and overall fidelity curves for the receiver are shown in figure 1-5. The solid curve indicates the fidelity of the audio-frequency amplifier with input applied between terminal 3 of the "AUDIO GAIN" control (16, figure 1-2) and ground, and with the "RF GAIN" control (12) at minimum. The broken curve indicates the overall fidelity at 2.5 mc; with AM. of 30 percent, "SELECTIVITY" switch (18) in the 13-kc position, and the "RF GAIN" control set for a 10-mw reference-level output. In each instance, the output is measured across a 600-ohm resistive load (the "AUDIO GAIN" control set at maximum).

1-29. REJECTION RATIOS. The image rejection ratios of the receiver at the high frequency end of each receiver band are shown in table IV. The 455-kc i-f rejection ratio of the receiver is 69 db with the receiver tuning mechanism set to tune in a 600-kc signal. This ratio, applicable to single conversion, improves with frequency for bands 1, 2, and 3. The 3955-kc i-f rejection ratio of the receiver, applicable to double conversion, is a minimum of 94 db with the receiver tuning mechanism set to tune in any signal within the frequency range of bands 4, 5, and 6.

1-30. AUTOMATIC VOLUME CONTROL. The a-v-c action maintains the receiver output constant within 14 db when the input is increased from two to 200,000 microvolts.

1-31. LINE SUPPLY REQUIREMENTS. A single-phase, 50- to 60-cycle a-c power source within the voltage range of 90 to 270 volts is required to provide input power to the receiver. Voltage taps on the primary winding of the receiver power transformer are provided for line voltages below or above the usual 115-volt source. For an a-c line voltage of 117 volts, the receiver current drain is 1.25 amperes and its power consumption is 130 watts. The maximum starting current is two amperes.

TABLE IV. IMAGE REJECTION RATIOS

Band No.	Frequency	Image Rejection Ratio	
		Voltage Ratio	DB
1	1.35 mc	60,000	95
2	3.40 mc	10,000	80
3	7.40 mc	4,000	72
4	14.50 mc	300,000	109
5	29.50 mc	50,000	94
6	54.00 mc	5,000	74

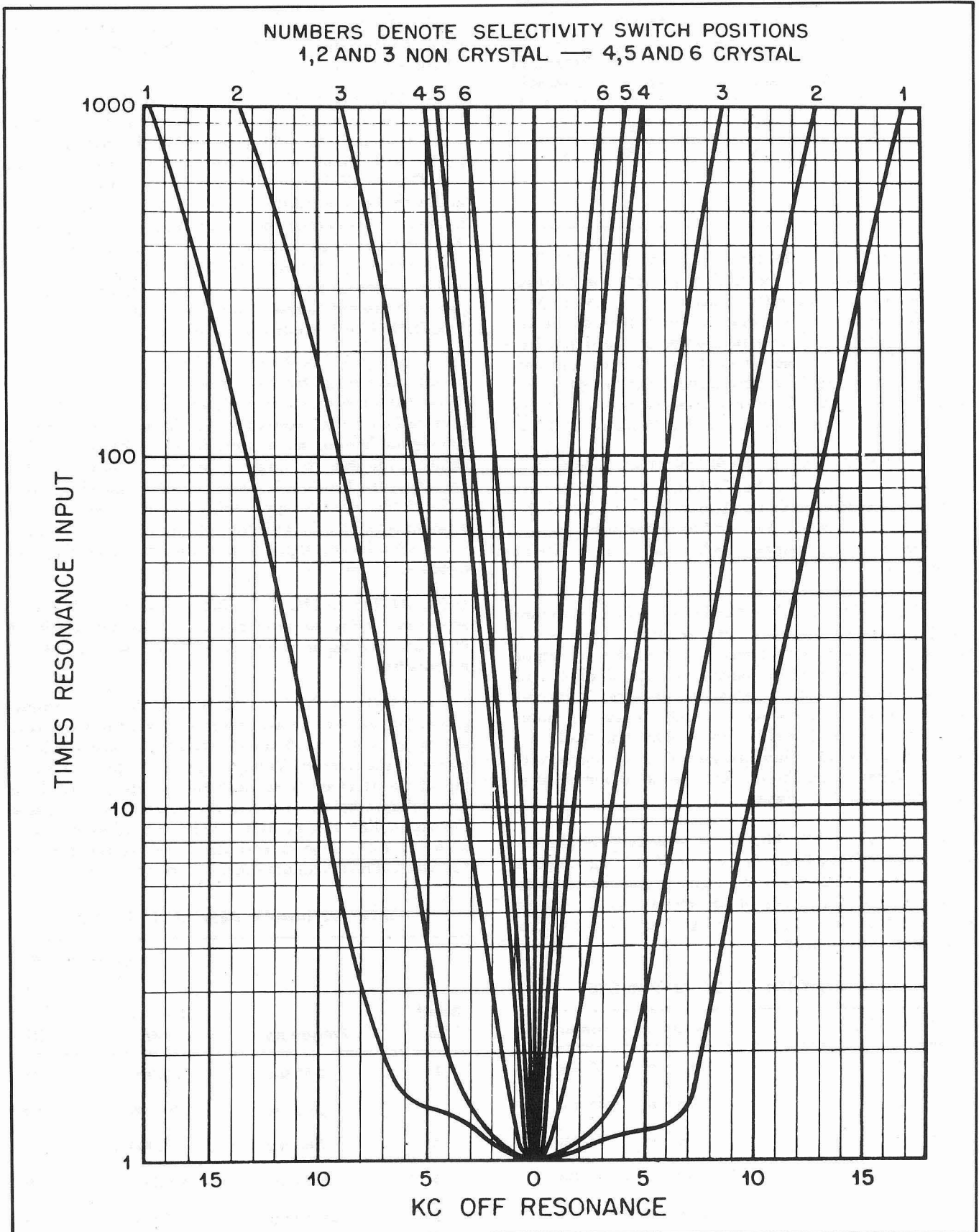

Figure 1-4. Overall Selectivity Curves at Two Megacycles

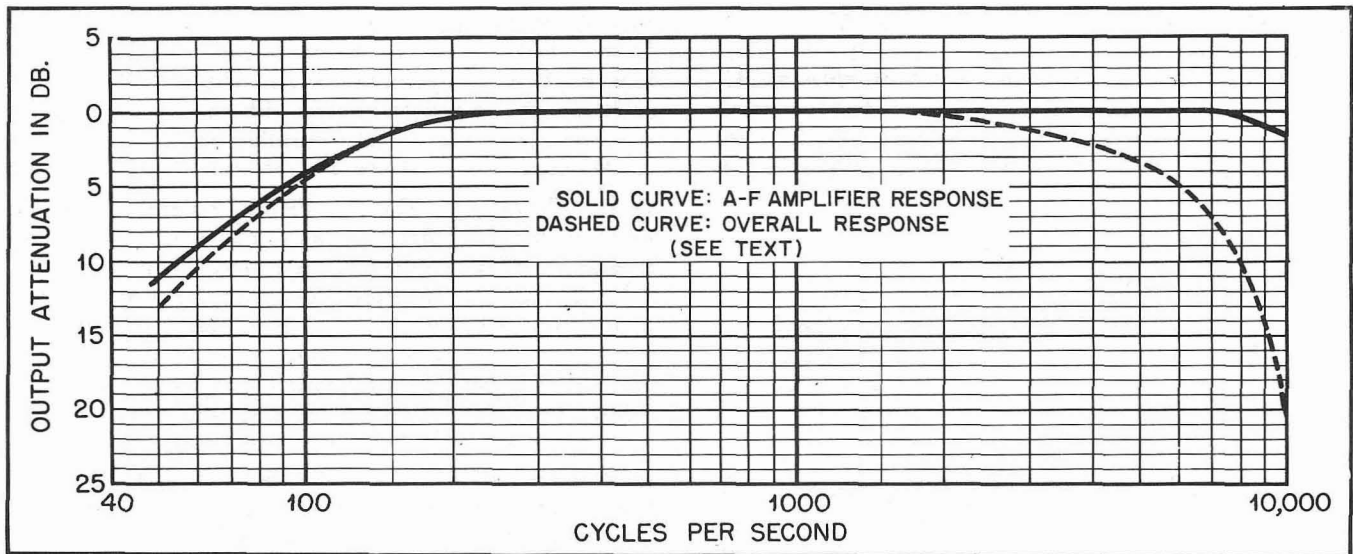

Figure 1-5. Audio and Overall Fidelity Curves

1-32. **TEMPERATURE AND HUMIDITY.** The receiver will perform satisfactorily in ambient temperatures ranging from 0°C (32°F) to 60°C (140°F) at a relative humidity as high as 95 percent.

1-33. OPERATING AND ADJUSTMENT CONTROLS.

1-34. The receiver operating and adjustment controls are located on the front panel (figure 1-2) and on the rear apron (figure 1-3), respectively. The controls are referred to below by their front-panel and rear-apron designations.

1-35. **"SEND/REC".** The "SEND/REC" switch (21, figure 1-2) is used to switch the receiver from its "REC" (receive) condition to a disabled "SEND" condition in the presence of a strong local carrier. When switched back to "REC", the receiver is ready for instant use.

1-36. **"MOD/CW".** The "MOD/CW" switch (13, figure 1-2) is used to control the beat frequency oscillator and the a-v-c time-constant network. In the "CW" position the bfo is turned on, and a long time constant is used for the avc. This position is used for suppressed-carrier and keyed-carrier reception, and also for frequency-shift reception when the receiver audio output is required for a frequency-shift converter, or the audio output is desired for aural monitoring. The "MOD" position is used for m-c-w reception. In this position the bfo is turned off and a short time constant is used for the avc.

1-37. **"BAND CHANGE".** The "BAND CHANGE" control (17, figure 1-2) is used to select the desired frequency band.

1-38. **"TUNING".** The "TUNING" control (15, figure 1-2) is used to tune in the signal.

1-39. **"TUNING LOCK".** The "TUNING LOCK" (14, figure 1-2) is used to lock the tuning mechanism at the tuning setting chosen.

1-40. **"SELECTIVITY".** The "SELECTIVITY" switch

(18, figure 1-2) provides a choice of "XTAL" (crystal) and three "NON-XTAL" (noncrystal) positions of receiver selectivity. The six positions provide selectivity steps ranging from a "SHARP" to a "BROAD" indication. The "XTAL" switch positions provide bandwidths of 0.2, 0.5, and 1.3 kc, and the "NON-XTAL" switch positions provide bandwidths of 3.0, 8.0, and 13.0 kc.

1-41. **"XTAL PHASING".** The "XTAL PHASING" control (1, figure 1-2) is used to attenuate heterodyne interference closely adjacent to the desired signal. It provides this function only when the "SELECTIVITY" switch (18) is in one of its three "XTAL" positions.

1-42. **"BEAT OSC."** The "BEAT OSC." control (10, figure 1-2) is used to vary the frequency of the bfo, as required for keyed-carrier and frequency-shift operation. The pitch of the tone or tones is dependent on the setting of the control. The control may be set on scale in either direction from its "O" position. It provides a plus and minus three-kc tone range. For suppressed-carrier m-c-w reception, the control, when set to its "O" position, provides the b-f-o output as the 455-kc reinserted carrier.

1-43. **"RF GAIN".** The "RF GAIN" control (12, figure 1-2) is used to switch the receiver on when turned clockwise from its "OFF" position to a point where a click is heard. Clockwise rotation of the control increases the r-f and i-f gain of the receiver. To prevent overloading the receiver r-f and i-f sections in manual operation, the control is turned down somewhat from the maximum position. The control is also turned down, when on avc, to reduce the sensitivity of the receiver during periods when the signal is off and fading, so that the undesirable noise output may be reduced.

1-44. **"AVC/MAN".** The "AVC/MAN" switch (11, figure 1-2) is used to switch from automatic to manual control of the receiver r-f and i-f gain. The "RF GAIN" control (12) is operative in both positions of the "AVC/MAN" switch.

1-45. "METER". The spring-return "METER" switch (3, figure 1-2) is associated with the tuning meter (2). In its normal "RF" position, the switch provides a calibrated r-f meter indication if the "RF GAIN" control (12) is fully clockwise. When the switch is held in its depressed "AF" position, it provides a calibrated a-f meter indication.

CAUTION

To avoid meter damage, set the "AUDIO GAIN" control (16, figure 1-2) fully counterclockwise, then depress the meter switch, and then slowly increase the audio level to the desired meter scale indication.

1-46. "AUDIO GAIN". The "AUDIO GAIN" control (16, figure 1-2) is used to adjust the receiver audio output to a comfortable level. The receiver audio output is adequate to operate any recording equipment carefully, but the receiver controls should be adjusted to provide undistorted output.

1-47. "LIMITER/OFF". The "LIMITER/OFF" switch (19, figure 1-2) controls a noise-limiting circuit. In the "LIMITER" position the limiter is operative, in the "OFF" position it is not. The switch should be kept in the "OFF" position, unless pulse-type noise is interfering with reception.

1-48. "FREQ CONTROL". The "FREQ CONTROL" switch (8, figure 1-2) controls the selection of the variable-frequency oscillator for variable-frequency operation, or the crystal-controlled oscillator for fixed-

channel operation on any of six preselected channels. In the "VFO" position, the continuously variable oscillator is placed in operation. In any of the six "XTALS" positions, the crystal associated with the switch position is connected to the crystal-controlled oscillator, and the crystal oscillator is placed in operation.

1-49. " Δ FREQ". The " Δ FREQ" control (7, figure 1-2) is used to tune in the signal when the fixed-frequency crystal-controlled first heterodyne oscillator is being used. The control provides a slight adjustment in the frequency of the oscillator, necessitated by the 0.005-percent frequency tolerance inherent in each crystal used. The panel markings designate an arbitrary frequency scale for the control setting. Clockwise rotation produces a relatively lower oscillator frequency.

1-50. "METER ADJ RF". The "METER ADJ RF" control (5, figure 1-3) is used to calibrate the r-f scale of the tuning meter (2, figure 1-2). With a 10-microvolt input signal and the "RF GAIN" control (12) fully on the "METER ADJ RF" control is set for an r-f meter scale reading of +20 db.

1-51. "METER ADJ AF". The "METER ADJ AF" control (7, figure 1-3) is used to calibrate the a-f scale of the tuning meter (2, figure 1-2). With a 600-ohm resistive load connected to the "AUDIO OUTPUT" terminals (8) and 1.9 volts or six milliwatts of audio output, the "METER ADJ AF" control is set to provide a zero-db a-f meter scale reading.

1-52. "BFO INJ". The "BFO INJ" control (4, figure 1-3) provides the means for adjusting the level of the b-f-o injection voltage applied from the buffer stage to the detector stage.

SECTION II

TEST EQUIPMENT AND SPECIAL TOOLS

2-1. TEST EQUIPMENT.

2-2. The test equipment required for testing, servicing, and aligning the radio receiver is listed in table V. No special test equipment is required.

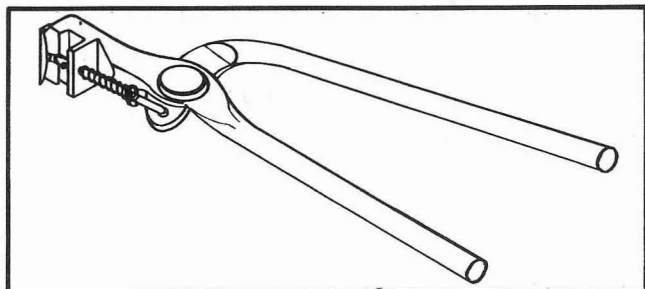

Figure 2-1. Special Pliers

2-3. SPECIAL TOOLS.

2-4. The special tools procured for the maintenance of the radio receiver are listed in table VI.

2-5. CABLE FABRICATION.

2-6. **ANTENNA CABLE.** The antenna cable is used to connect the signal generator to the antenna input connector of the receiver for test or alignment purposes. It comprises the parts shown in figure 2-2.

2-7. **CATHODE FOLLOWER CABLE.** The cathode follower cable is used to connect the output meter to the i-f output connector for test purposes. It comprises the parts shown in figure 2-3.

TABLE V. TEST EQUIPMENT REQUIRED FOR MAINTENANCE

Name	AN Type Designation	Alternate	Use
Electronic Multimeter	ME-74/U	ME-6A/U	A-c voltmeter and db meter (useful to 500 kc)
Electronic Multimeter	AN/USM-34	ME-25A/U	General purpose vtvm and ohmmeter
Audio Oscillator	TS-382A/U	Hewlett-Packard 200AB	Audio response tests
RF Signal Generator Set	AN/URM-25	Precision E-200-C	Alignment and testing, 10-kc to 50-mc A-M signal generator
RF Signal Generator Set	AN/URM-26	Precision E-200-C	Alignment and testing, 3-mc to above 54-mc A-M signal generator
Signal Generator	TS-447/U	Hickok Model 188	Alignment and testing, sweep generator covering 445 kc and 3955 kc
Cathode Ray Oscilloscope	OS-9/U	DuMont Model 208	Used with sweep generator for alignment purposes
Tube Tester	AN/USM-31	TV-3A/U	Tube checking

TABLE VI. SPECIAL TOOLS REQUIRED FOR MAINTENANCE

Figure	Hammarlund Part No.	Name	Application
2-1	T8222	Pliers, special	Removal and replacement of flat spring for r-f tuners

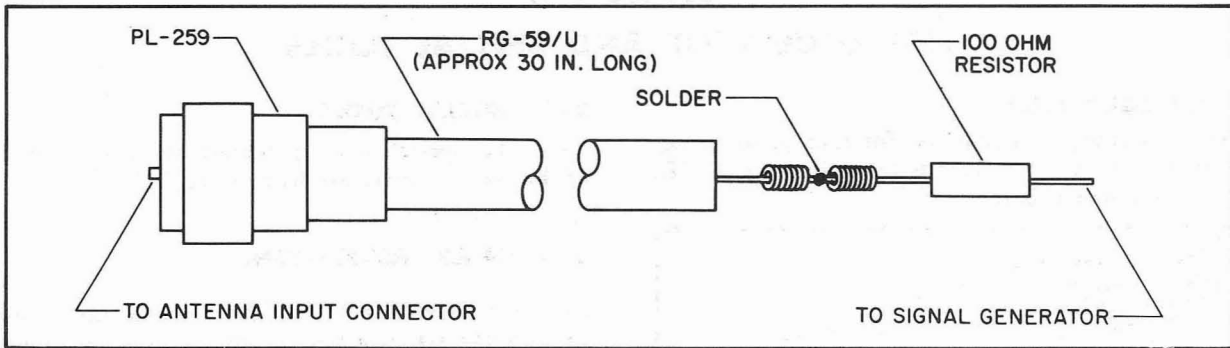

Figure 2-2. Antenna Cable

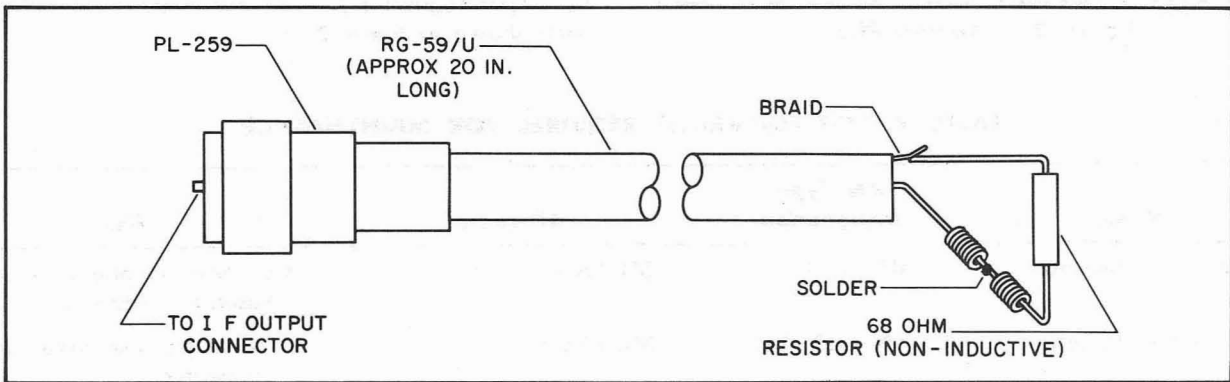

Figure 2-3. Cathode-follower Cable

SECTION III

PREPARATION FOR USE AND RESHIPMENT

3-1. PREPARATION FOR USE.

3-2. UNCASING.

3-3. The radio receiver is packed for shipment at the factory. An outer wooden case encloses a carton which contains the receiver proper and a bag containing the receiver cable plug connectors, which are removed from the receiver for shipment. Unpack the equipment as follows:

- a. Cut the steel straps, close to the wooden case cover, and fold them back.
- b. Remove the cover.
- c. Remove the carton containing the receiver and plug connectors from the case.
- d. Remove the waterproof tape from the waterproof covering wrapped around the carton; remove the waterproof paper wrapper and open the carton.
- e. Remove the wood frame from the carton; also the accordion-folded corrugated interiors comprising two side pieces, one front, one back, and one top. Remove the bag containing the receiver plug connectors.
- f. Remove the receiver and place it out of the way, in a convenient place near its final location.
- g. Remove the receiver plug connectors from the outer cloth, inner paper bag, and plastic bags.
- h. Put all packing material in the wooden case and store.

3-4. SETTING UP RECEIVER.

3-5. PRIMARY TAP USED. When shipped, the radio receiver power transformer primary tap is connected to operate from a 50- to 60-cycle, 117-volt a-c source. Table VII shows the a-c source voltage rating of each primary tap, identified by the numerical designation assigned it on the bottom of the power transformer.

**TABLE VII. POWER TRANSFORMER TAP
VOLTAGE RATINGS**

Tap No.	Voltage Rating
2	95
3	105
4	117
5	130
6	190
7	210
8	234
9	260

CAUTION

Choose the power transformer primary tap whose voltage rating is in closest agreement with the a-c source voltage.

3-6. PLUG CONNECTOR ASSEMBLIES. Each plug connector assembly removed from the receiver for shipment is listed in table VIII. As it is unpacked, connect each plug to the receiver.

3-7. PREPARATION FOR RESHIPMENT OR STORAGE.

3-8. When the radio receiver is to be reshipped or to be stored subsequent to use, remove the frequency control unit crystals, as instructed in paragraph 5-15, and remove the plug connector assemblies listed in table VIII. Fully mesh the eight-section, four-gang variable air capacitor and then pack the receiver as described in paragraph 3-9.

3-9. To pack the receiver, proceed as follows:

- a. Open the folded receiver carton and tape all edges with three-inch gummed kraft paper tape.
- b. Accordion-fold the ends of a corrugated cardboard bottom for the carton, to act as a spring-board bottom for the receiver. Place it in the carton with the accordion folds downward.
- c. Place the receiver in the carton and cover the receiver panel with wrapping paper.
- d. Put into the carton, around the receiver, accordion-folded corrugated interiors, comprising two side pieces, one front, one back, and one top, with the accordion folds against the walls of the carton; also put in one wood frame to act as a carton spacer.

**TABLE VIII. PLUG CONNECTOR ASSEMBLIES
REMOVED FROM RECEIVER FOR SHIPMENT**

Reference Symbol	Government Type Designation	Connects To
P2	Antenna Input Plug UG-102/U	Antenna adapter connector P3
P3	Antenna Adapter Connector UG-104/U	"ANT" input jack (J1, figure 5-4)
P4	PL-259	"IF OUTPUT" connector (6, figure 1-3)

e. Put the receiver plug connectors listed in table VIII into the plastic bags, press the bags to exhaust as much air as possible, and heat-seal. Place the plastic bags into the paper and cloth bags, and place in the carton at the side of the receiver.

f. Complete the taping of the carton, using the three-inch tape.

g. Wrap the carton in waterproof paper and seal all folds with three-inch waterproof tape.

h. Put the waterproof-wrapped carton into the wooden case.

i. Nail the cover on the wooden case and put two steel straps around the case.

j. Stencil all markings on the end of the case and affix an address label on the side.

SECTION IV

THEORY OF OPERATION

4-1. GENERAL SYSTEM OPERATION.

4-2. The radio receiver is designed for use in single- or multi-receiver military installations. Where required, two or more receivers may be used in a space-diversity arrangement. In this system, each receiver is connected to a separate antenna and the antennas arranged in proper space relationship to each other. The receivers may be interconnected to provide a common a-v-c system and/or common audio output, as required.

4-3. The receiving system provides for reception of A-M, c-w, or frequency-shift signals. Receiver output may be in the form of audio signals, available at the "PHONES" jack (20, figure 1-2) or at the "AUDIO OUTPUT" terminals (8, figure 1-3); d-c signals, available at the "DIODE OUTPUT" terminals (2); or 455-kc signals, available at the "IF OUTPUT" connector (6).

4-4. RECEIVING SYSTEM BLOCK DIAGRAM.

4-5. A typical space-diversity system for the reception of frequency-shift teletype signals is illustrated in block form in figure 4-1. Space-diversity systems make use of the fact that signals induced in antennas five to ten wavelengths apart fade separately. Each receiver has a separate antenna and the two antennas are suitably spaced in relation to each other. The output signal, in this instance, is supplied from the "IF OUTPUT" connectors of both receivers. The a-v-c systems of the two receivers are interconnected at the "AVC" terminals (3, figure 1-3) on the rear apron.

4-6. In space-diversity operation, the signals induced in the two antennas vary in intensity, depending upon propagation characteristics. In any event, the receiver with the stronger input signal develops the larger a-v-c voltage and supplies the output signal to the frequency-shift converter equipment. Since the two a-v-c systems are interconnected, the large a-v-c voltage developed in the receiver with the stronger input signal reduces the gain of the other receiver to reduce its noise output. When conditions reverse, the action of the two receivers reverses also, and the output signal is supplied by the second receiver. The frequency-shift converter equipment converts the i-f signal to a d-c signal suitable for operating a teletype-writer unit.

4-7. For other possible receiving systems, refer to the handbook of operation instructions for the radio receiver.

4-8. RECEIVER FUNCTIONAL OPERATION.

4-9. RECEIVER BLOCK DIAGRAM. Figure 4-2 shows in block form the relationship existing among the internal circuits of the receiver. Indicated in each block are the tube type and schematic symbol designation of the electron tube associated with each stage. The

receiver is a superheterodyne type using single conversion on frequencies below 7.4 mc and double conversion on frequencies above 7.4 mc. The antenna input circuit is designed for a balanced doublet or a single-wire antenna system.

4-10. The signal voltage induced into the antenna circuit is applied to a two-stage, tuned r-f amplifier, comprising tubes V1 and V2 and their associated circuitry. A rotary turret assembly is employed to change bands by inserting the proper coil assemblies into the r-f amplifier circuits. The two tuned stages of r-f amplification provide a high degree of image rejection and selectivity, and a high signal-to-noise ratio. The gain of the r-f amplifiers is established by the setting of the "RF GAIN" control (12, figure 1-2) in manual operation and, additionally, by the a-v-c voltage developed by the incoming signal when a-v-c operation is employed. The signal selected and amplified in the r-f amplifier circuits is applied to the frequency conversion section of the receiver.

4-11. The first frequency conversion section of the receiver comprises the first mixer stage and either a crystal-controlled, fixed-frequency heterodyne oscillator stage or a variable-frequency heterodyne oscillator stage. The selection of the heterodyne oscillator circuit is accomplished by means of the "FREQ CONTROL" selector switch (8, figure 1-2). When the switch is rotated to the "VFO" position, a variable-frequency heterodyne oscillator is selected, and its output applied to the injection grid of first mixer tube V5. Variable-frequency oscillator tube V4, with its associated circuitry, comprises an Armstrong-type oscillator circuit on the lower three bands of the receiver and a Colpitts-type circuit on the three higher bands. The rotary turret assembly inserts the proper oscillator tank elements into the circuit for each band. When the "FREQ CONTROL" selector switch is rotated to one of its six "XTALS" positions, the variable-frequency oscillator is disabled and a fixed-frequency, crystal-controlled heterodyne oscillator is placed in operation. Tube V3 and its associated circuitry comprise an electron-coupled Pierce-type oscillator circuit whose frequency is established by the crystal inserted into the selected crystal socket. On the three lower receiver bands, the heterodyne oscillators operate 455 kc above the frequency of the incoming signal; on the three higher bands of the receiver, the oscillator frequency is 3955 kc above the signal frequency. The incoming signal and the output of the heterodyne oscillator are applied to pentagrid mixer tube V5 and heterodyne-detected in the first mixer stage. The output of the stage is either 455 kc or 3955 kc, depending upon the frequency band selected. On the three lower frequency

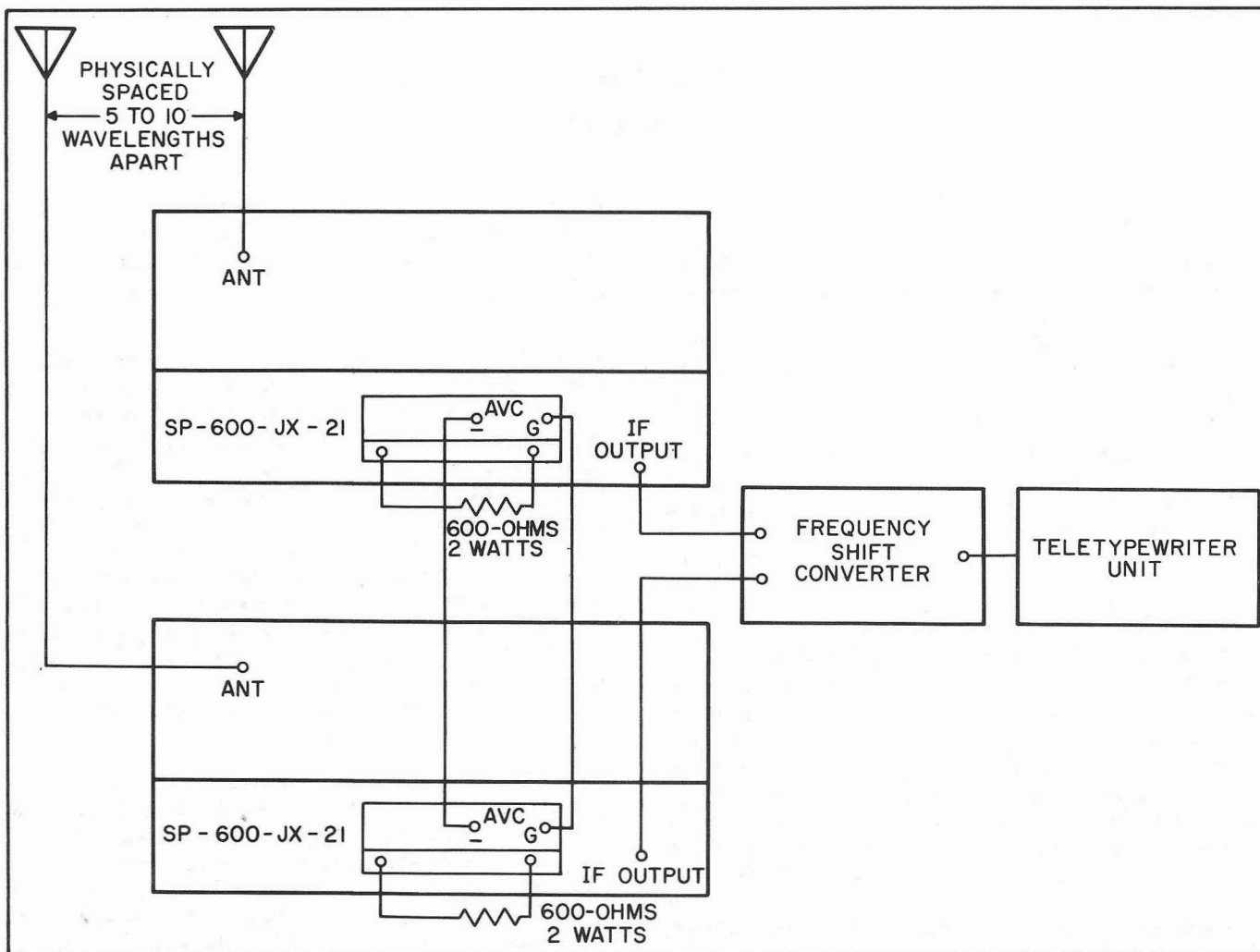

Figure 4-1. Space-diversity Reception of Frequency-shift Signals, System Block Diagram

bands, the 455-kc output signal is applied to tube V7 in the gate circuit; a switch ganged to the "BAND CHANGE" control (17, figure 1-2) applies d-c power to the gate tube and disables the 3.5-mc crystal oscillator and the second mixer; and the 455-kc i-f signal passes through the gate circuit and is applied to the i-f amplifier section. The gate circuit provides some i-f amplification but its primary purpose is to provide a signal path for the 455-kc i-f signal.

4-12. On the three upper frequency bands of the receiver, signal conversion to an if. of 455 kc is unable to provide suitable image rejection in the r-f section of the receiver. The heterodyne oscillators are therefore designed to operate 3955 kc above the frequency of the incoming signal. When the two frequencies are heterodyne-detected in the first mixer stage, a 3955-kc if. results. Before application to the i-f amplifiers, the signal must be converted to the 455-kc frequency to which the i-f circuits are tuned. This second frequency conversion is accomplished in the second mixer circuit. A

switch ganged to the "BAND CHANGE" control disables the 455-kc i-f gate circuit and applies power to the 3.5-mc crystal oscillator tube V8 and to second mixer tube V6. The 3.5-mc triode crystal oscillator circuit becomes operational and provides a signal for the injection grid of the second mixer tube. The 3955-kc signal from the first mixer is applied to the signal grid of the same tube. The two frequencies are heterodyne-detected in the second mixer circuit and an if. of 455 kc results. Through use of the double-conversion system, the advantages of high gain obtainable with a low if., and good image rejection obtainable with a high if. are both realized.

4-13. The 455-kc signal from the second mixer stage, or from the gate stage, is applied to a crystal filter circuit. The front-panel "SELECTIVITY" switch (18, figure 1-2) provides receiver bandwidths of 0.2 kc, 0.5 kc, 1.3 kc, 3 kc, 8 kc, and 13 kc, with the crystal filter circuit providing the three sharp degrees of selectivity. The crystal, in conjunction with the "XTAL PHASING" control (1), provides extreme selectivity for the attenuation of closely adjacent interfering signals.

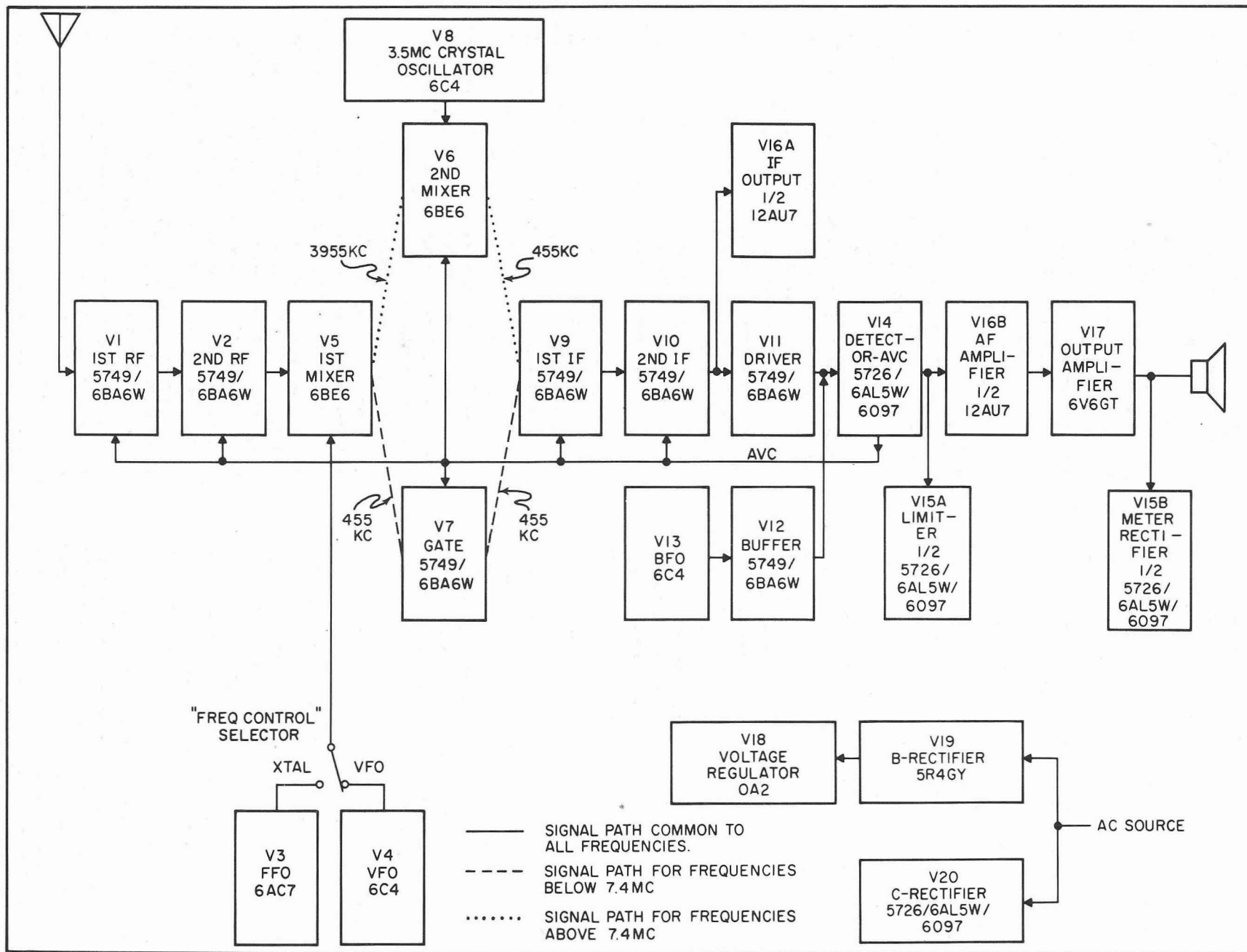

Figure 4-2. Radio Receiver, Block Diagram

Paragraphs 4-14 to 4-21

4-14. The first and second i-f amplifier stages are electrically similar. Tubes V9 and V10, with their circuitry, comprise tuned voltage amplifier circuits. The gain of the stages is established by the setting of the "RF GAIN" control (12) in manual operation and, additionally, by the a-v-c voltage developed when a-v-c operation is used. The i-f transformers are specially designed, with four secondary windings providing different coefficients of coupling between primary and secondary. The "SELECTIVITY" switch, in its three broad positions, is used to select the secondary winding with the appropriate coefficient of coupling for the bandwidth desired. The output of the second i-f amplifier is applied to driver tube V11 and to i-f output tube V16A. The driver stage comprises a fixed-biased voltage amplifier designed to provide a suitable driving signal to the second detector and a-v-c rectifier stages. The i-f output stage, a cathode-follower circuit, is designed to provide a 455-kc i-f signal at a power level suitable for a 70-ohm load.

4-15. The b-f-o and buffer stages are used in the c-w mode of operation. The "MOD/CW" switch (13, figure 1-2), in its "CW" position, applies power to b-f-o tube V13 and the b-f-o circuit becomes operational. The b-f-o stage employs a high-capacity Colpitts circuit designed for good frequency stability and low harmonic output. The nominal b-f-o frequency is 455 kc, variable within limits of ± 3 kc by means of the "BEAT OSC." control (10). The buffer stage, comprising tube V12 and its circuitry, reduces the possibility of oscillator lockin and permits variation of the b-f-o injection voltage by means of the "BFO INJ" control (4, figure 1-3) on the rear apron of the receiver. The output of the buffer is combined with the i-f signal in the plate circuit of driver tube V11 and applied to the second detector.

4-16. Tube V14A, with its circuitry, functions as a diode detector circuit. The audio output of the stage is applied through the "AUDIO GAIN" control (16, figure 1-2) to the a-f amplifier section of the receiver. A shunt-type noise limiter, comprising tube V15A and its circuitry, is connected in parallel with the output load circuit. When the "LIMITER/OFF" switch (19) is set to the "LIMITER" position, the limiter circuit shunts pulse-type noise interference to ground and reduces the noise pulses from the receiver output. The a-v-c rectifier circuit, comprising tube V14B and its circuitry, serves to limit fluctuations in output level due to variations in signal input to the receiver. For maximum weak signal sensitivity, a delayed a-v-c system is employed. The a-v-c voltage, when the "AVC/MAN" switch (11) is in the "AVC" position, is applied to both r-f amplifiers, the second mixer, the gate, and the first and second i-f amplifier stages. The a-v-c circuit may be used for both A-M and c-w reception.

4-17. A two-stage audio amplifier section, comprising tubes V16B and V17 and their circuitry, develops the required audio output power. The first audio amplifier stage is a cathode-biased, resistance-capacitance coupled, triode voltage amplifier whose output voltage drives the grid of tube V17. The output amplifier is a cathode-biased, beam-power amplifier circuit whose output is

transformer-coupled to the load. The output amplifier furnishes a maximum of two watts of undistorted power to a 600-ohm load connected to the "AUDIO OUTPUT" terminals (8, figure 1-3) on the rear apron. A separate winding on the output transformer furnishes a lower-level audio signal for application to an 8000-ohm headset connected to the "PHONES" jack (20, figure 1-2). The meter rectifier circuit is connected in parallel with the audio output circuit. Tube V15B functions as a half-wave rectifier which rectifies the audio output voltage and applies the resultant d-c voltage to the tuning meter (2) when the "METER" switch (3) is held in its "AF" position. The scale of the meter is calibrated in db, with zero db corresponding to the standard reference level of 6 milliwatts.

4-18. The operating potentials for the tubes in the receiver are furnished by the power supply, an integral part of the receiver. Tube V19 and its circuitry comprise a full-wave rectifier with a two-section pi-type filter. The B-rectifier furnishes maximum d-c potentials of +305 volts and +265 volts unregulated and, in conjunction with the voltage regulator circuit associated with tube V18, +150 volts regulated. The C-rectifier, comprising tube V20 and its circuitry, is a full-wave rectifier circuit with a three-section L-type filter. The C-rectifier furnishes a maximum of -51 volts for application to the bias circuits of the receiver. The power transformer is provided with screw terminal primary taps covering a power source range of 90 to 270 volts, 50 to 60 cps. The power transformer and filter elements are protected by fuses in the primary and plate supply circuits.

4-19. FUNCTIONAL OPERATION OF MECHANICAL COMPONENTS. The easily operated "BAND CHANGE" control (17, figure 1-2) controls a rotor turret assembly which inserts the proper r-f tuner sub-assemblies into the r-f circuits of the receiver. The frequency band selected is indicated at the "MEGACYCLES" window (5) and a movable pointer associated with the main tuning dial (4) indicates the frequency band in use. The compact turret assembly provides excellent receiver sensitivity at high signal-to-noise ratios.

4-20. The receiver "TUNING" control (15, figure 1-2) is specially designed to permit maximum traverse speed and exceptional operating ease. It controls both the main tuning dial and the vernier dial (6). An anti-backlash gear train provides extremely close calibration accuracy. The "TUNING LOCK" (14) provides positive locking action without affecting the frequency setting. The "TUNING LOCK", when used, clamps the vernier dial and locks the gear train driven by the "TUNING" control. The "TUNING" control itself remains free to turn. The tuning ratio between the "TUNING" control and the main tuning dial is 50 to 1, and the ratio between the vernier dial and the main dial is 6 to 1.

4-21. All adjustable cores of the slug-tuned inductors and all trimmer capacitors are spring-loaded to maintain their adjustment settings. The adjustment controls on the rear apron of the receiver are of the screwdriver-adjusted type, to minimize the possibility of accidental misadjustment.

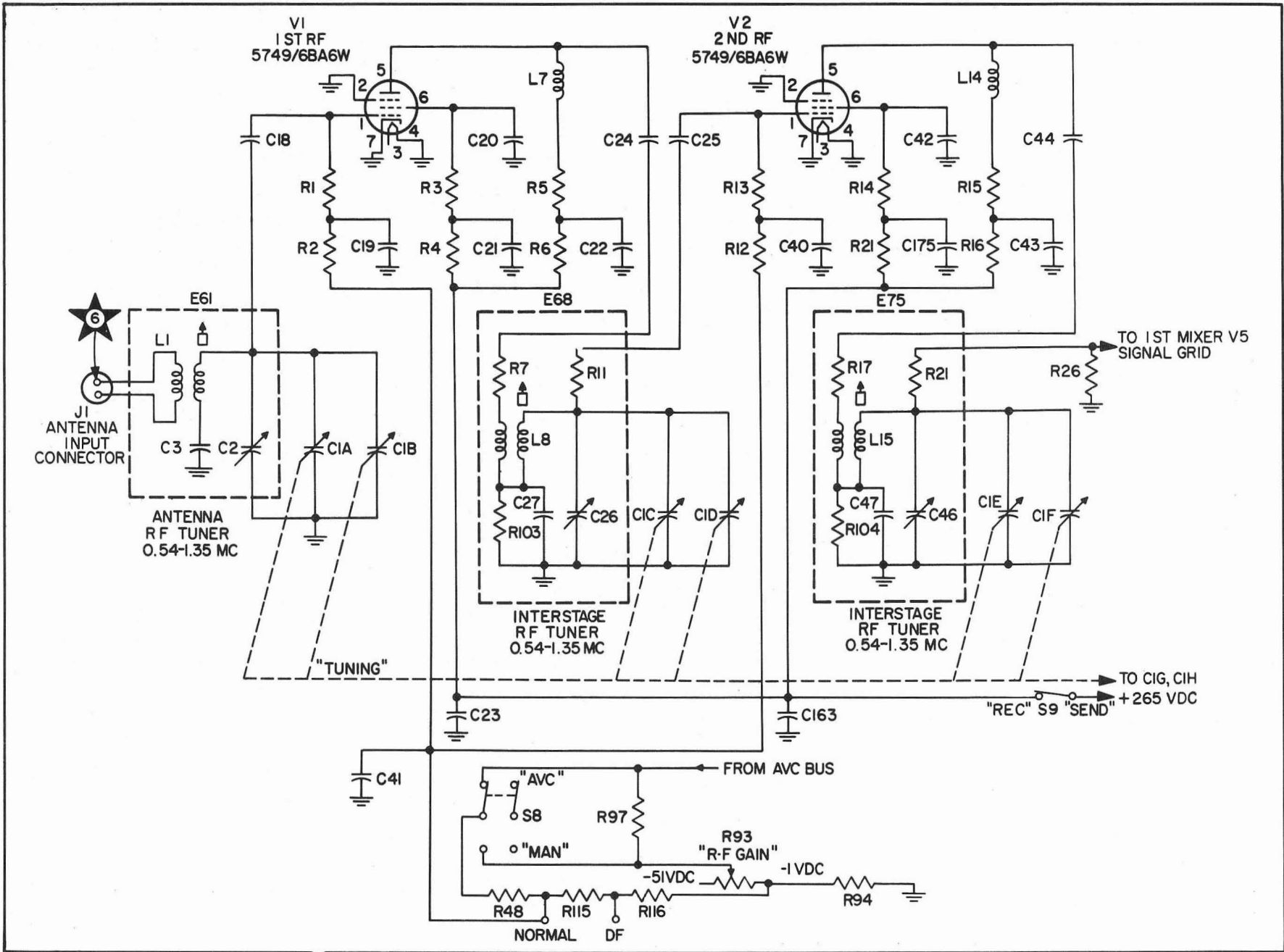

Figure 4-3. Radio-frequency Amplifiers, Schematic Diagram

4-22. SIMPLIFIED CIRCUIT THEORY.

4-23. GENERAL. A schematic analysis of the receiver circuits is given in paragraphs 4-24 through 4-60. The radio receiver provides continuous coverage over a frequency range of 0.54 mc to 54.0 mc in six bands. The "BAND CHANGE" control (17, figure 1-2) positions a rotary turret assembly which inserts the proper r-f tuner subassemblies for each band into the r-f amplifier circuits and the circuit of the variable-frequency heterodyne oscillator. All simplified schematic circuit diagrams show the circuit elements used on the 0.54-to-1.35-mc band. The antenna input circuit of the receiver is designed to match a 95-ohm transmission line. A balanced doublet or a single-wire antenna installation may be used.

4-24. R-F AMPLIFIERS. (See figure 4-3.) Two double-tuned r-f amplifier stages utilizing 5749/6BA6W pentode tubes comprise the input stages of the receiver. These r-f amplifiers, whose bias can be controlled either manually by the "RF GAIN" control or automatically from the a-v-c circuit, increase the amplitude of the r-f signals supplied from the antenna system, provide for an increased signal-to-noise ratio, and provide a high order of image and adjacent-channel signal rejection.

4-25. Balanced antenna input transformer L1, resonated by sections C1A and C1B of the "TUNING" control, is an impedance matching device which applies the r-f signals through coupling capacitor C18 to the control grid of first r-f amplifier tube V1. Capacitor C2 is used to trim the tank circuit at the upper end of the band, and the slug in the secondary of L1 is used for tracking at the low end. The first r-f amplifier has a shunt-fed plate circuit in which the +265-volt potential is applied through "SEND/REC" switch S9, dropping resistor R6, decoupling network C22-R5, and r-f choke L7 to the plate of tube V1. The screen is decoupled from the supply voltage by means of resistor R4 and capacitor C21. Resistor R3 is the screen dropping resistor; capacitor C20 is the screen bypass. R-f plate current flows through coupling capacitor C24 and limiting resistor R7 into the primary of interstage r-f transformer L8. The bottom end of transformer L8 is held at r-f ground potential by means of capacitor C27. The signals induced in the secondary of transformer L8 are applied through parasitic suppressor R11 and coupling capacitor C25 to the control grid of second r-f amplifier tube V2. The selectivity of the stage, as well as its overall gain, is maintained relatively constant over the tuning range of the band by the complex interstage coupling network. The bias for the stage is determined by the setting of "RF GAIN" control R93. For manual volume-control operation, the "RF GAIN" control is placed at the setting that provides maximum signal input without overloading and optimum signal-to-noise conditions. For automatic operation, the "RF GAIN" control is usually set to its maximum clockwise position and the a-v-c potential, applied through decoupling network R2-C19 and grid-return resistor R1 to the control grid, is used to control the gain of the stage. The "RF GAIN" control is always operative, even in automatic operation, and may

be used to control the overall r-f gain of the stage. For direction-finding applications where greater sensitivity and greater selectivity are required, the bias lead is removed from the "NORMAL" link and placed on the "DF" link. In the "DF" position, the a-v-c potential is less than that in the "NORMAL" position and the tuning response is made sharper, since the a-v-c potential does not have so great a tendency to broaden the tuning indication.

4-26. The second r-f amplifier is identical to the first r-f amplifier except for the input circuit which is part of the interstage coupling network. The "SEND/REC" switch is used to disable the receiver by removing plate and screen potentials from both r-f amplifiers whenever the switch is placed in the "SEND" position. The output of the second r-f amplifier is applied to the signal grid of first mixer tube V5.

4-27. SINGLE-CONVERSION CIRCUITS. (See figures 4-4 and 4-5.) When the "BAND CHANGE" control is set to one of the three lower frequency bands, single conversion is used in the receiver. The frequency conversion circuits utilized on these three bands are the first mixer, the variable-frequency heterodyne oscillator or the fixed-frequency heterodyne oscillator, and the gate circuit. A conversion switch ganged to the "BAND CHANGE" control disables the second-conversion circuits. In the single-conversion mode of operation, the heterodyne oscillator circuits operate at a frequency 455 kc above the frequency of the incoming signal and the output of the first mixer stage is a 455-kc i-f signal. This signal is applied to the crystal filter circuit through the path provided by the gate circuit. The first mixer and heterodyne oscillator circuits are also used for double conversion; however, to provide adequate image rejection, the heterodyne oscillators operate 3955 kc above the frequency of the incoming signal and a 3955-kc i-f signal results. The conversion switch disables the gate circuit, when the "BAND CHANGE" control is set to one of the three upper bands, and applies power to the second-conversion circuits to automatically change from single conversion to double conversion for all signal frequencies above 7.4 mc.

4-28. The first mixer consists of a pentagrid tube and associated circuitry. Two inputs are applied to the stage. One input is obtained from the r-f amplifiers and is applied to the signal grid of pentagrid mixer tube V5. The other is obtained from the first heterodyne oscillator (i.e., from either fixed-frequency oscillator tube V3 or variable-frequency oscillator tube V4) and is applied to the injection grid of the pentagrid mixer. The plate circuit of the mixer contains two parallel resonant networks which are connected in series. One of these networks is resonant at 455 kc and presents negligible impedance at 3955 kc; the other is resonant at 3955 kc and presents negligible impedance at 455 kc. Thus only the 455-kc conversion frequency is developed in the plate circuit when operating on the three lower bands, and only the 3955-kc conversion frequency is obtained when operating on the three higher bands. The network comprised of capacitor C69 and slug-tuned in-

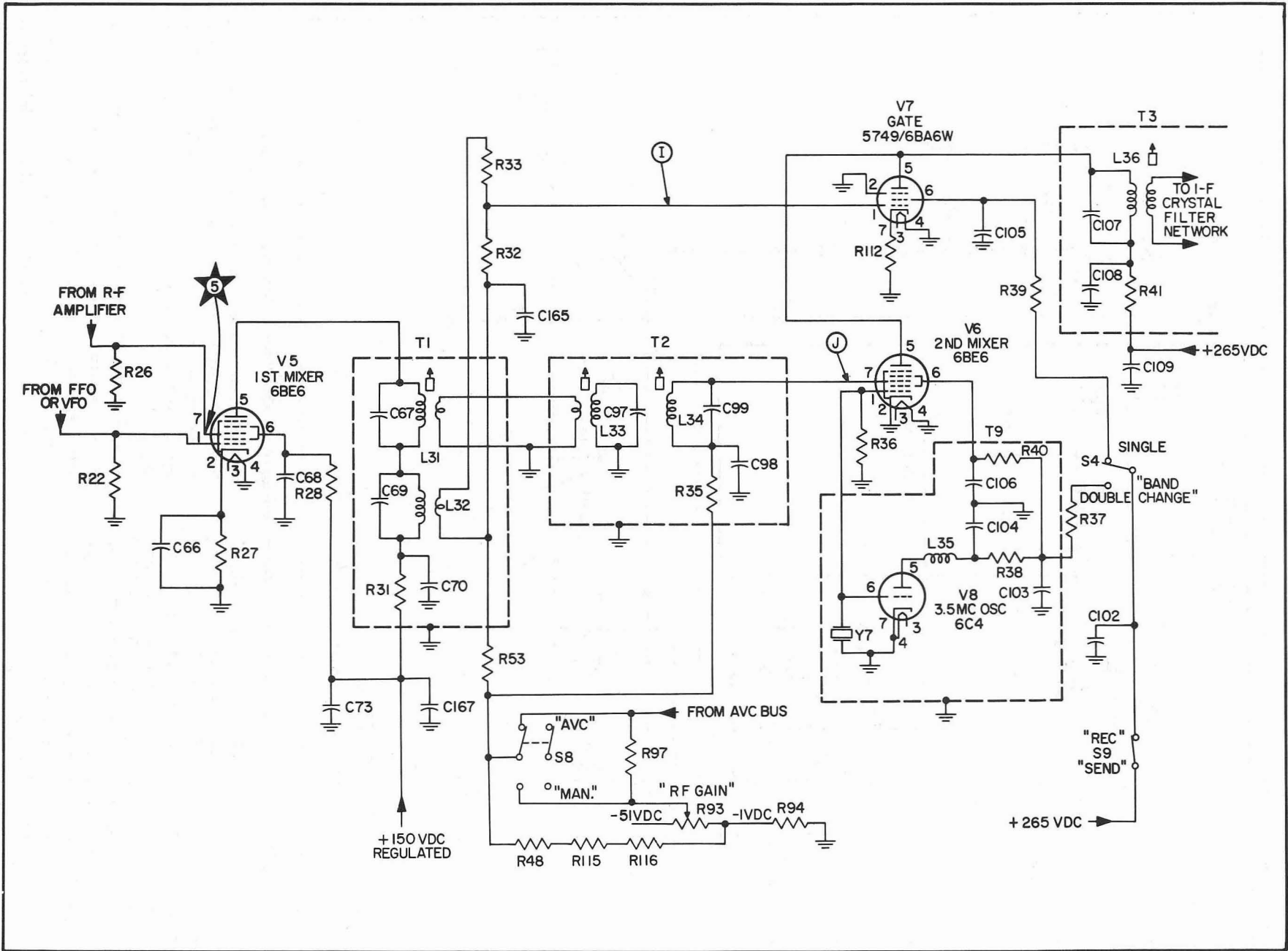

Figure 4-4. Single- and Double-conversion Circuits, Schematic Diagram

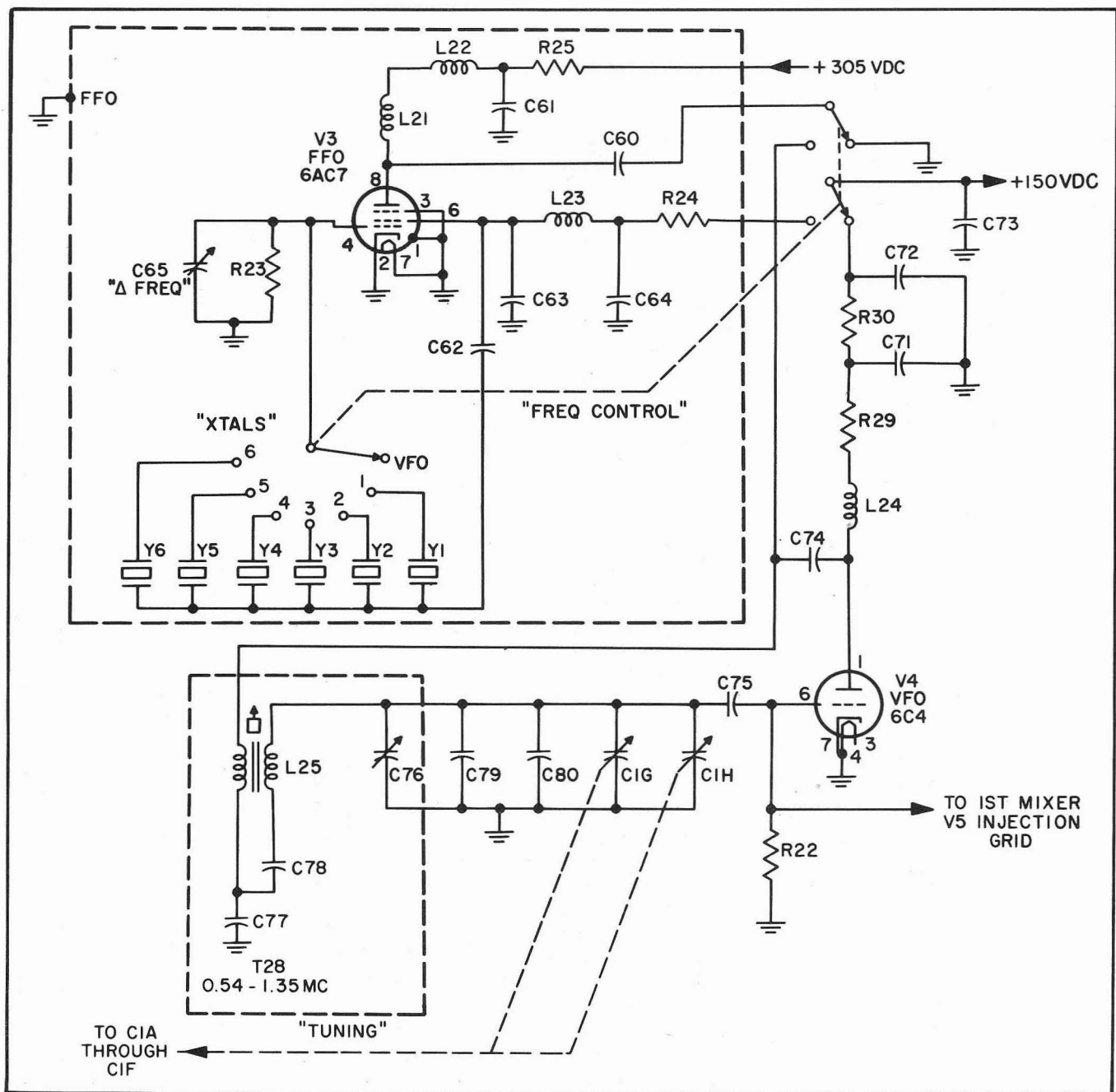

Figure 4-5. Fixed-frequency and Variable-frequency Oscillators, Schematic Diagram

ductor L32 is resonant at 455 kc and is used for single-conversion operation. The heterodyne products resulting from the mixing of the r-f and local-oscillator signals flow through the complex plate load and only the 455-kc signals are developed. A portion of the signal developed across voltage divider resistors R32 and R33 is applied to the control grid of gate tube V7. The output of the gate circuit is applied to the crystal filter circuit. Plate and screen potentials to the first mixer are applied through decoupling networks that consist of R31-C70 and R28-C68, respectively. Cathode bias for the stage is provided by resistor R27, which is bypassed by

capacitor C66. For double-conversion operation, on the three higher bands, only the 3955-kc conversion signals are developed (across the C67-L31 tank circuit) and applied to the second mixer by means of transformer coupling.

4-29. The fixed-frequency heterodyne oscillator is an electron-coupled crystal-controlled oscillator of the Pierce type. It utilizes a 6AC7 pentode and associated circuit items. The stage is one of two which are available for use as the first heterodyne oscillator. The other is the variable-frequency oscillator stage. The B potentials

for each tube are applied through the contacts of a switch common to both tubes so that only one of these oscillators can be operative at a given time. The screen, control grid, and cathode of tube V3 are utilized for the oscillator circuitry. When "FREQ CONTROL" selector switch S2 is in any of its six "XTALS" positions, the crystal-controlled oscillator is operative at the frequency determined by the particular crystal in use. The oscillator signals are coupled to the plate circuit through the electron flow within the tube and are developed across plate load inductors L21 and L22. The plate circuit is decoupled from the +280-volt supply by means of the C61-R25 network. Coupling capacitor C60 applies the oscillator signals to the frequency-determining tank circuit of the variable-frequency oscillator. The output signals are applied to the tank circuit of the variable-frequency oscillator, which is correctly tuned when the "TUNING" control is set to the carrier frequency. Coupling capacitor C75 applies the fixed-frequency oscillator signals across grid-return resistor R22, from which point they are applied to the injection grid of the first mixer. " Δ FREQ" control C65 in series with capacitor C63 shunts the crystal of the fixed-frequency oscillator and provides a small amount of control over the operating frequency of the stage. This control is provided to compensate for slight variations in crystal frequency, temperature and/or voltage variations, or other conditions which might cause the oscillator to operate slightly off the desired frequency. The screen circuit is isolated from the +150-volt potential and held at an r-f potential by means of r-f choke L23, whose low end is decoupled from the supply voltage by means of decoupling filter C64 and R24. When "FREQ CONTROL" selector switch S2 is in the "VFO" position, the fixed-frequency oscillator is disabled and the plate circuit is grounded for rf.

4-30. The variable-frequency oscillator, utilizing a 6C4 triode, is connected as an Armstrong (or tickler)-type circuit on the first three bands, and as a Colpitts-type circuit on the last three bands. The network contained in r-f tuner T28 is shunted by temperature-compensating capacitors C79 and C80 and by tuning-capacitor sections C1G and C1H. Feedback from plate circuit to grid circuit is provided by coupling capacitor C74 and the tickler winding of inductor L25. The plate of tube V4 is maintained at r-f potential by r-f choke L24. Resistor R24 in series with L24 tends to maintain a uniform impedance over the tuning range. The plate circuit is decoupled from the +150-volt potential which is applied through contacts of "FREQ CONTROL" selector switch S2 by means of the pi-type decoupling network comprising C71-R30-C72. The oscillator signals are applied to the injection grid of the first mixer through stabilizing resistor R21.

4-31. The gate circuit is a pentode i-f amplifier which utilizes a 5749/6BA6W tube. Switch S4, which is ganged to the "BAND CHANGE" control, applies the screen potential on the three lower bands and removes the screen potential to disable the gate circuit on the three higher bands. The plate potential for this stage is applied through the primary windings of i-f interstage

transformer T3. The plate circuit of first mixer tube V5 contains two independent parallel-resonant circuits which comprise the primary windings of interstage transformer T1. As described in paragraph 4-28, the L32 winding is resonant to 455 kc and the L31 winding is resonant to 3955 kc. Thus, when operating on the first three bands, only the 455-kc signals are developed in the output of the first mixer and applied to the gate whose prime function is to provide a signal path for the 455-kc signals to the i-f amplifiers. The voltage-divider action of R33 and R32 reduces the signal input to the gate so that the amplified output of the gate stage does not overload the crystal filter. A small amount of negative feedback is introduced by unbypassed bias resistor R112 to stabilize the stage. The gain of the gate circuit is controlled either manually by "RF GAIN" control R93, or automatically by the a-v-c potential.

4-32. DOUBLE-CONVERSION CIRCUITS. (See figure 4-4.) When the "BAND CHANGE" control is turned to one of the three upper frequency bands, one section of the switch disables the gate stage and applies power to the second-conversion circuits comprising the second mixer stage and the 3.5-mc crystal oscillator stage. The output from the first mixer stage on the three upper bands is a 3955-kc signal which is applied to the signal grid of the second mixer tube. A 3.5-mc signal from the 3.5-mc crystal oscillator stage is applied to the injection grid and the two signals are heterodyne-detected in the second mixer stage. The 455-kc output of the second mixer is applied to the crystal filter circuit.

4-33. The second mixer stage utilizes a type 6BE6 pentagrid mixer tube. On the three upper bands of the receiver, the 3955-kc signal developed in transformer T1 is link-coupled to transformer T2 and applied to the signal grid of second mixer tube V6. Two mutually coupled, tuned circuits are utilized in transformer T2 to improve the selectivity of the circuit. The 3.5-mc signal from oscillator tube V8 is direct-coupled to the injection grid of mixer tube V6. The two signals are heterodyne-detected in the second mixer stage, and the difference frequency of 455 kc is developed across the plate load comprising inductor L36 and capacitor C107, which is parallel resonant at 455 kc. Plate voltage is supplied to tube V6 from the +265-volt output of the B-rectifier through plate decoupling resistor R41 and the primary of i-f transformer T3. Screen voltage is supplied from the same +265-volt source through "SEND/REC" switch S9, conversion switch S4, decoupling resistor R37, and screen dropping resistor R40. Capacitors C108 and C109 are plate decoupling capacitors; capacitors C102 and C103 are decoupling capacitors in the screen circuit; and capacitor C106 is the screen bypass capacitor. Bias voltage is applied to the signal grid from "RF GAIN" control R93 and, in a-v-c operation, from the a-v-c bus. Resistor R35 and capacitor C98 comprise the grid decoupling filter network.

4-34. The 3.5-mc crystal oscillator stage utilizes a type 6C4 tube in a crystal-controlled triode oscillator circuit, which is electrically equivalent to a tuned-plate, tuned-grid oscillator circuit. The frequency of oscillations is

accurately established at 3.5 mc by crystal Y7. The 3.5-mc. signal output is applied from the grid of the 3.5-mc oscillator to the injection grid of the second mixer. Plate voltage is supplied to tube V8 from the +265-volt output of the B-rectifier through "SEND/REC" switch S9, conversion switch S4, decoupling resistor R37, plate dropping resistor R38, and plate inductor L35. Capacitors C102 and C103 are decoupling capacitors and capacitor C104 is the plate bypass capacitor. A small amount of grid-leak bias voltage is developed across grid-return resistor R36.

4-35. CRYSTAL FILTER CIRCUIT. (See figure 4-6.) The crystal filter is incorporated into the i-f section of the receiver to provide a higher degree of selectivity than is obtainable using ordinary transformer-coupled

circuits, and to attenuate highly the amplitude of adjacent channel signals by utilizing the crystal as a variable-frequency filter. The first of these purposes is achieved through the inherent sharp frequency-response of the crystal; the second is achieved by making use of the fact that the crystal and its holder comprise a series L-C-R network shunted by the capacity of the crystal holder. This network can be made parallel-resonant at frequencies above or below the series-resonant point of the crystal by changing the effective shunt capacity of the crystal holder. When the "SELECTIVITY" switch is set to one of its three crystal positions, the crystal, series-resonant to 455 kc, is inserted in series between the input and output circuits of the i-f transformer at the input of the first i-f stage, and functions as the coupling element between the two circuits. A capacitive bridge

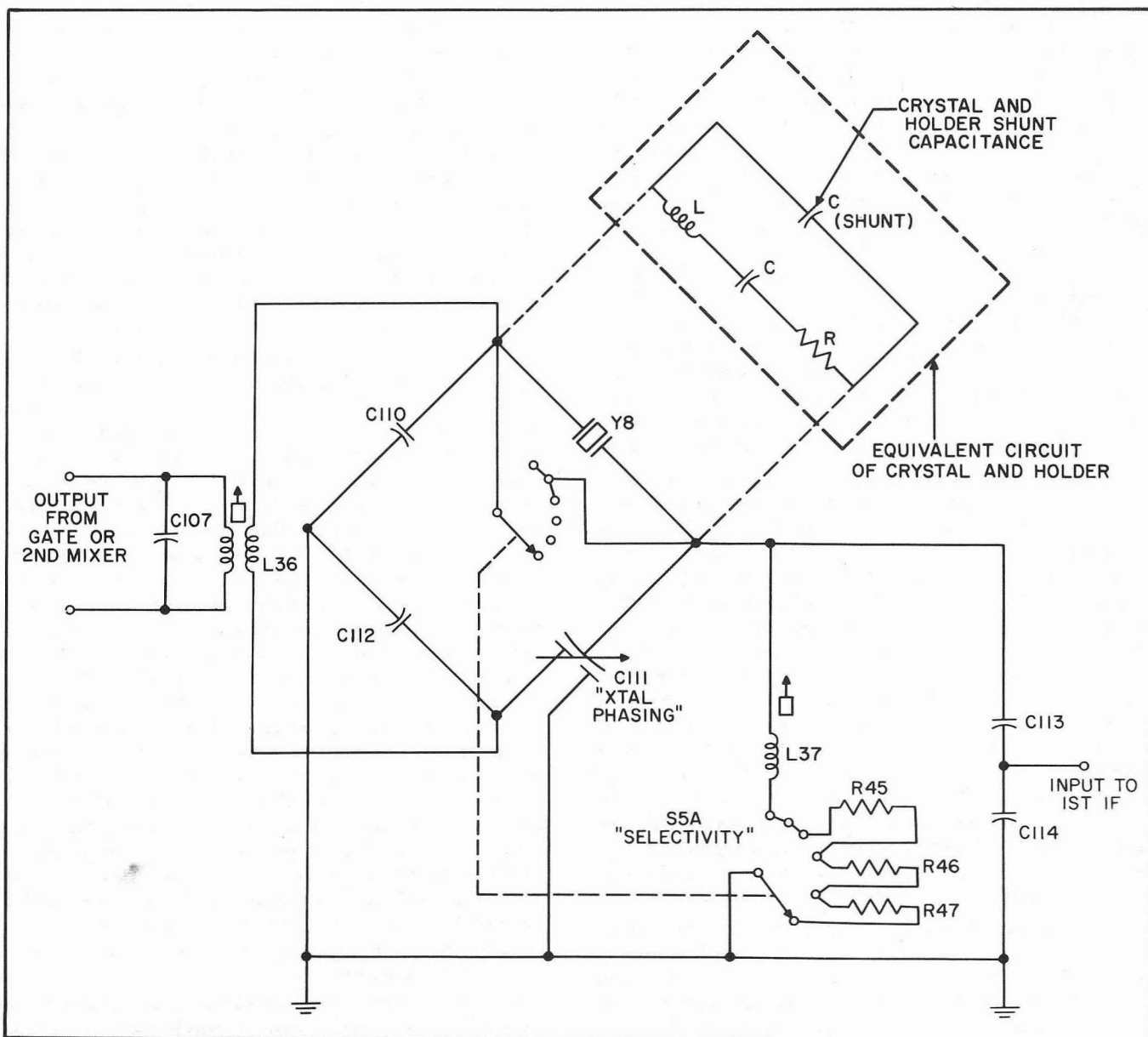

Figure 4-6. 455-kc Crystal Filter, Simplified Schematic Diagram

network is used to change the value of the shunt capacity of the crystal and its holder. This neutralizing circuit can be underneutralized or over-neutralized by means of the "XTAL PHASING" control. When the circuit is underneutralized, the crystal, in parallel with the effective shunt capacitance, forms a parallel-resonant circuit at a frequency slightly higher than 455 kc. The parallel combination offers a high impedance to any signal at the parallel-resonant frequency and sharply attenuates this signal. The desired 455-kc signal utilizes the low impedance of the series-resonant crystal, which provides a coupling path, and the signal undergoes negligible attenuation. By overneutralizing the bridge network, frequencies below 455 kc may be rejected in a similar fashion.

4-36. When "XTAL PHASING" control C111 is set to the diamond between its positions "4" and "6", the effective shunt capacitance of the crystal and its holder is neutralized. The 455-kc signal input to the filter is applied from the gate tube in the single-conversion mode, or from the second mixer in the double-conversion mode, and developed across the parallel-resonant circuit comprising capacitor C107 and the primary of inductor L36. The voltage induced into the secondary circuit of inductor L36 is applied to the series combination of crystal Y8 and the output tank circuit which comprises inductor L37 and capacitors C113 and C114. If the incoming signal coincides with the series-resonant frequency of the crystal (i.e., 455 kc), the crystal, being series-resonant, acts like a virtual short circuit; the output tank circuit, being parallel-resonant, presents a high impedance; and the signal appears across the high impedance of the output tank circuit with negligible attenuation. If the incoming signal frequency is some value other than 455 kc, the series impedance of the crystal at this frequency is high; the impedance of the output tank circuit is reduced; voltage divider action takes place and the signal developed across the output tank circuit is highly attenuated. The selectivity of a series-resonant circuit depends upon its series resistance; therefore, different degrees of selectivity are attainable by varying the effective resistance in series with the crystal. "SELECTIVITY" switch S5A provides the means for inserting resistors R45, R46, and R47 into the parallel-resonant output tank circuit. With no resistance in the circuit, the parallel-resonant circuit presents a high resistive impedance, and the resulting crystal selectivity is broad. As the resistance in the tank circuit is increased, the "Q" of the tank circuit decreases; the effective resistance presented by the tank circuit decreases; with less effective resistance in series with the crystal, the selectivity of the crystal filter increases. The voltage output of the crystal filter circuit is developed across capacitor C114 in the output tank circuit and applied to the first i-f stage.

4-37. "XTAL PHASING" control C111 is arranged in a bridge circuit with capacitors C110, C112, and the shunt capacitance of the crystal and its holder. The input terminals of the bridge are connected to the sec-

ondary of inductor L36; the output terminals are connected to the output tank circuit. When "XTAL PHASING" control C111 is properly adjusted, the bridge is balanced, and no voltage is coupled through the shunt capacity of the crystal to the output circuit. The only coupling possible under these conditions is through the series impedance of the crystal itself, as discussed in paragraph 4-36, above. If the setting of the "XTAL PHASING" control is changed, the circuit becomes unbalanced. If the circuit is underneutralized, a capacitive current is shunted around the crystal; if overneutralized, an inductive current results. In the presence of many interfering signals, the shunt paths provided around the crystal reduce the effectiveness of the filter; however, by proper adjustment of the "XTAL PHASING" control, the shunt impedance can be effectively utilized to reject a single undesired carrier. If the circuit is underneutralized, the resultant shunt capacitance will form a parallel-resonant circuit with the crystal at some frequency above 455 kc. The exact parallel resonant frequency depends upon the value of the unneutralized shunt capacitance; the value of this capacitance depends upon the setting of the "XTAL PHASING" control; therefore, the "XTAL PHASING" control provides the means of tuning the parallel-resonant circuit formed by the crystal and its shunt capacitance. In the presence of an interfering signal closely adjacent in frequency to the desired signal, "XTAL PHASING" control C111 can be varied until the effective shunt capacitance resonates with the crystal at the frequency of the interfering signal. The parallel-resonant combination presents a much higher impedance than that attainable with the crystal alone and the interfering signal is highly attenuated.

4-38. The adjustable slugs of inductors L36 and L37 provide the means for aligning the input and output circuits to the crystal frequency. "XTAL PHASING" control C111 is a dual-stator capacitor with its two sections arranged in such a manner as to minimize the possibility of detuning the input and output circuits as the control is varied. When "SELECTIVITY" switch S5A is set to any of its noncrystal positions, one section of the switch shorts out the crystal, and resistors R45, R46, and R47 are removed from the output tank circuit. The selectivity characteristics of the receiver are then established by the first and second i-f stage transformers.

4-39. I-F AMPLIFYING CIRCUITS. (See figure 4-7.) The i-f amplifier section of the receiver comprises tubes V9, V10, V11, and V16A, and their circuitry. The first and second i-f amplifier stages are electrically similar. Both are tuned voltage amplifiers with bias voltage established by the setting of the "RF GAIN" control and, in a-v-c operation, by the voltage developed in the a-v-c circuit. The output of the second i-f amplifier is applied to the i-f output stage and to the driver stage. The i-f output stage, a cathode-follower circuit, furnishes a 455-kc output signal available at the "IF OUTPUT" connector. It is designed to match a 70-ohm load. The driver stage utilizes a fixed-biased power-amplifier circuit which develops the necessary power for application to the detector and a-v-c circuits.

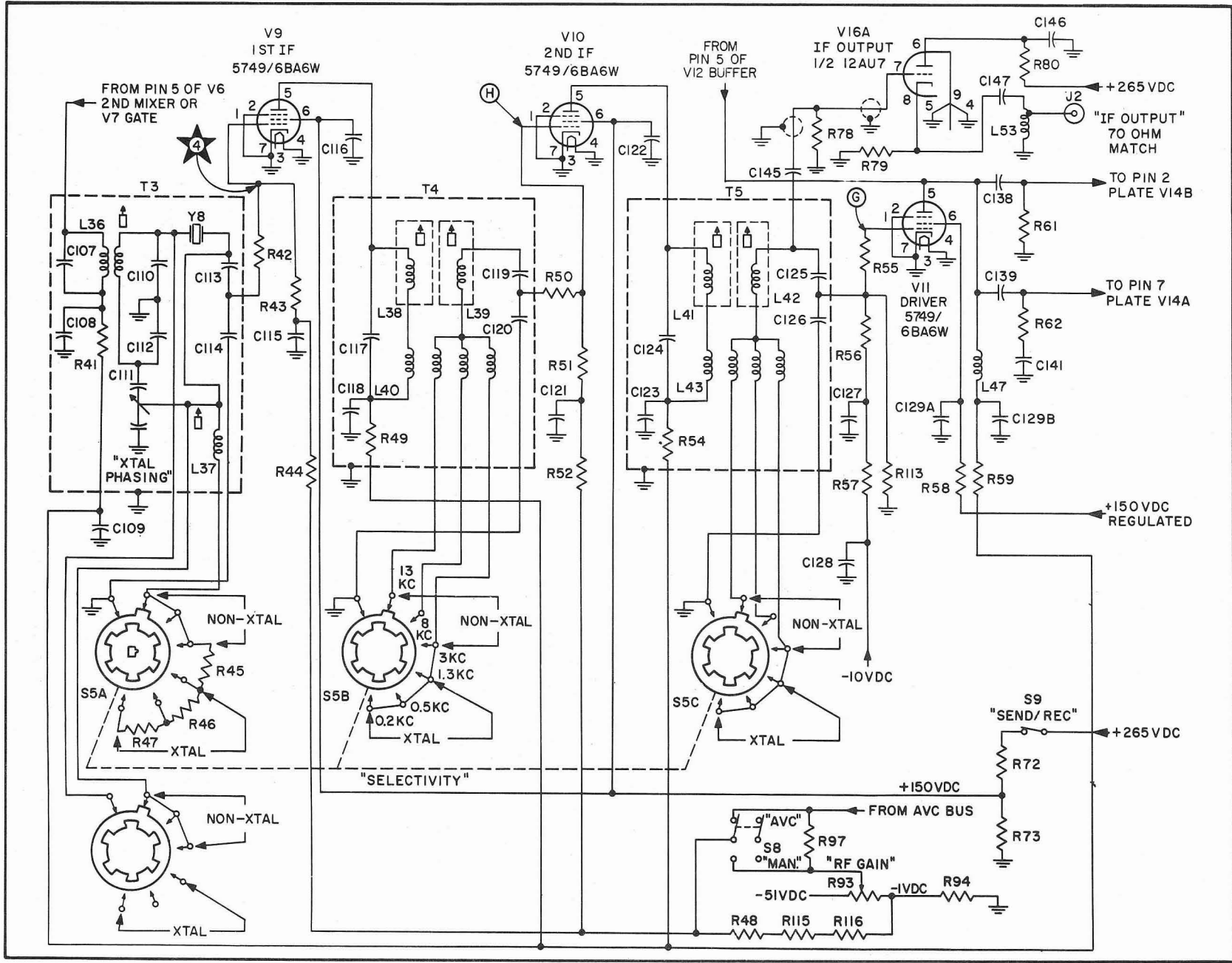

Figure 4-7. 455-kc Intermediate-frequency Amplifier Circuits, Schematic Diagram

4-40. The first i-f stage utilizes tube V9, a type 5749/6BA6W tube. D-c plate voltage is applied to the tube from the +265-volt output of the B-rectifier, through plate decoupling resistor R49 and the primary of i-f transformer T4. Screen voltage is applied from a voltage divider comprising resistors R72 and R73, which are connected across the +265-volt output of the B-rectifier. "SEND/REC" switch S9, when actuated to the "SEND" position, disables the first and second i-f stages by removing the screen voltage. Capacitor C116 is the screen bypass capacitor and capacitor C118 is the plate decoupling capacitor. Bias voltage is applied to the control grid through grid decoupling resistor R44 and grid return resistor R43. Capacitor C115 is part of the grid decoupling filter. The 455-kc input signal is applied from the crystal filter circuit, through grid stabilizing resistor R42, to the control grid of tube V9. The amplified 455-kc i-f output signal is developed across the tuned primary circuit of transformer T4, comprising inductor L38, capacitor C47, and the primary of inductor L40. Inductor L40 has three secondary windings arranged to provide different coefficients of coupling between primary and secondary. "SELECTIVITY" switch S5 provides the means for inserting any one of the three secondary windings of L40 into the tuned secondary circuit of transformer T4. Since the selectivity of a double-tuned transformer depends upon the coefficient of coupling, three degrees of noncrystal selectivity are available with this arrangement. The tuned secondary circuit of transformer T4 comprises inductor L39, capacitors C119 and C120, and the selected secondary of inductor L40. The voltage developed across capacitor C120 is applied through grid stabilizing resistor R50 to the grid of second i-f tube V10. Inductors L38 and L39 are slug-tuned to the 455-kc if.

4-41. The second i-f stage is electrically similar to the first i-f stage. The 455-kc signal applied from the secondary circuit of transformer T4 is further amplified in this stage, and coupled through transformer T5 to the i-f-output and driver stages. Transformer T5 is identical to transformer T4 and functions in a similar manner.

4-42. The 455-kc voltage developed across the secondary windings of transformer T5 is coupled to the control grid of i-f output tube V16A by means of capacitor C145 and resistor R78. Tube V16A and its circuitry comprise a cathode-follower circuit. The 455-kc output signal is developed across resistor R79 in the cathode circuit and coupled to "IF OUTPUT" connector J2 by means of capacitor C147 and impedance-matching auto-transformer L53. Plate voltage is applied to the tube from the +265-volt output of the B-rectifier through decoupling resistor R80. The plate is maintained at i-f ground potential by decoupling capacitor C146. The cathode follower circuit is designed to provide approximately 200 millivolts of 455-kc signal to a 70-ohm load.

4-43. The 455-kc voltage developed across capacitor C126 in the secondary circuit of transformer T5 is applied to the control grid of driver tube V11 through grid stabilizing resistor R55. The driver stage, a power amplifier, obtains bias voltage from a voltage divider

comprising resistors R57, R56, and R113 which are connected across the -10-volt output of the C-rectifier. Resistor R57, in conjunction with capacitors C127 and C128, also serves as a grid decoupling filter. Plate voltage is supplied from the +265-volt output of the B-rectifier through decoupling resistor R59 and plate load inductor L47. Screen voltage is supplied from the regulated +150-volt supply through decoupling resistor R58. Capacitor C129A is the screen decoupling capacitor; capacitor C129B is the plate decoupling capacitor. The amplified output signal of the stage is developed across inductor L47 and applied through capacitors C138 and C139 to the a-v-c and detector stages, respectively. Inductor L47 also serves as the plate load for buffer tube V12. When the c-w mode of operation is selected, the 455-kc i-f signal and the nominal 455-kc b-f-o signal from the buffer are combined in common plate load inductor L47 and the composite output signal applied to the detector and a-v-c circuits.

4-44. B-F-O AND BUFFER STAGES. (See figure 4-8.) The b-f-o and buffer circuits are used in the c-w mode of operation. The b-f-o stage utilizes a Colpitts circuit to generate a signal of 455 kc, adjustable within limits of ± 3 kc by means of the "BEAT OSC." control. The b-f-o circuit is operative when the "MOD/CW" switch is in the "CW" position. The buffer stage isolates the bfo to minimize the possibility of oscillator lockin and also provides the means for adjusting the b-f-o injection voltage.

4-45. The b-f-o stage utilizes a type 6C4 tube and its circuitry, arranged in a high-capacity Colpitts-type oscillator circuit. The design of the circuit provides a high order of frequency stability and low harmonic output. The frequency of oscillation is established at a nominal 455 kc by the tank circuit comprising inductors L44, L45, and L46 and capacitors C130, C131, and C132. The front-panel "BEAT OSC." control provides the means for varying the core position of inductor L45 to adjust the oscillator frequency over a range of ± 3 kc. The core of inductor L44 is also adjustable and provides the means for calibrating the dial of the "BEAT OSC." control. Regulated +150-volt plate voltage is applied to the tube through "MOD/CW" switch S7, plate decoupling resistor R77, and plate resistor R76. Capacitor C133 couples the 455-kc voltage from the plate circuit back to the tank circuit to maintain oscillations. Grid bias voltage is developed by grid-leak capacitor C134 and grid-leak resistor R75. The nominal 455-kc signal developed across inductor L46 in the tank circuit is direct-coupled to the grid of buffer tube V12.

4-46. The buffer stage utilizes a type 5749/6BA6W tube in a power amplifier circuit. It is designed to prevent lockin between the oscillator and the receiver 455-kc i-f signal, and to develop the necessary power to meet the load requirements imposed by the detector and a-v-c circuits. Tube V12 obtains its d-c plate and screen grid voltages from the +265-volt output of the B-rectifier. The d-c plate voltage is applied through decoupling resistor R59 and plate inductor L47; the d-c screen grid voltage is applied through screen dropping re-

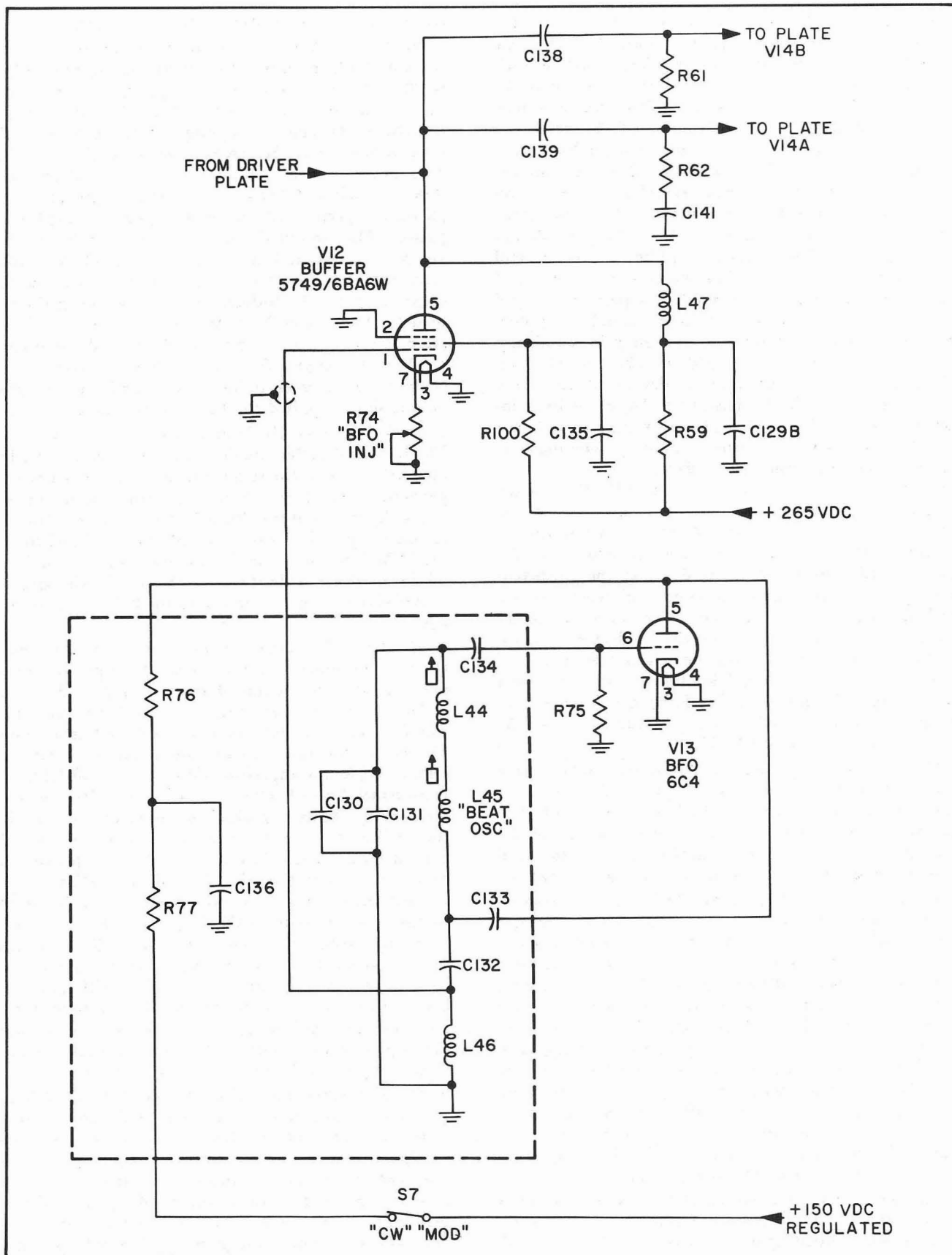

Figure 4-8. Beat-frequency Oscillator and Buffer Circuits, Schematic Diagram

sistor R100. Capacitor C135 is the screen bypass capacitor and capacitor C129B is the plate decoupling capacitor. Self-bias voltage is developed across "BFO INJ" control R74, which provides the means for adjusting the b-f-o injection voltage to the driver plate circuit by varying the stage gain. The 455-kc input signal is direct-coupled from the bfo to the control grid; the amplifier output is developed across inductor L47 which is common to both the buffer and driver stages.

4-47. DETECTOR, NOISE-LIMITER AND A-V-C CIRCUITS. (See figure 4-9.) The radio receiver utilizes a diode detector circuit with inherent characteristics of good fidelity and good signal handling capabilities. The 455-kc input signal is detected in the circuit and the audio component applied to the a-f section of the receiver. A diode, shunt-type, noise-limiter circuit is included to reduce pulse-type noise from the audio output. The 455-kc signal is also applied to the a-v-c circuit

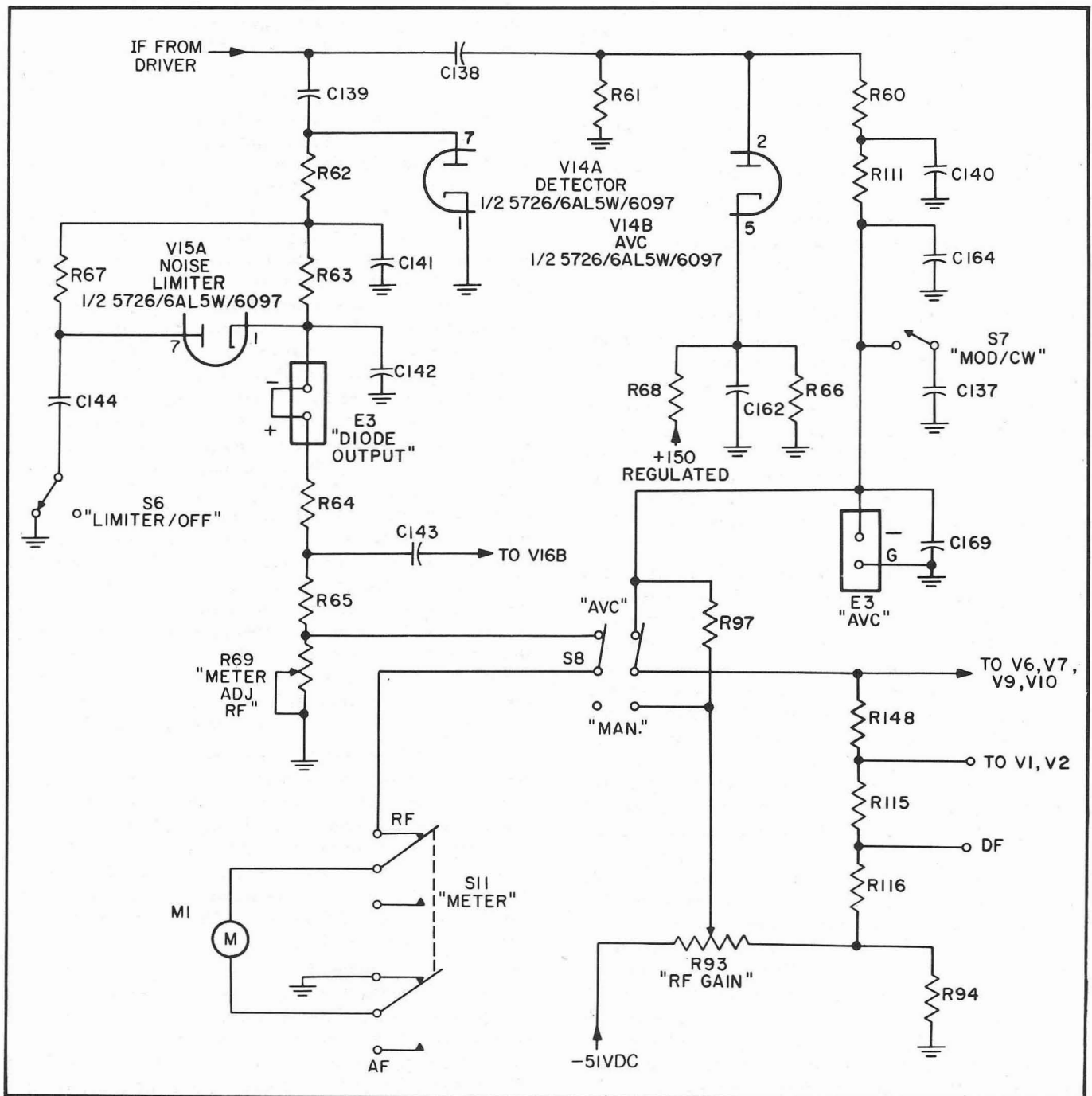

Figure 4-9. Detector, Noise-limiter and A-V-C Circuits, Schematic Diagram

Paragraphs 4-48 to 4-53

where it is rectified and applied to the a-v-c bus to automatically regulate the receiver output level. The "RF GAIN" control establishes the initial bias on the a-v-c bus in the absence of a signal. The a-v-c circuit may be used in the c-w mode of operation as well as in A-M reception.

4-48. The detector utilizes tube V14A, one section of a type 5726/6AL5W/6097 tube. The 455-kc input signal is applied from the driver circuit through capacitor C139. Tube V14A conducts on the positive excursions of the signal and charges capacitor C139. On the negative signal excursions, tube conduction is zero and capacitor C139 supplies a current through load resistors R62, R63, R64, and R65 and potentiometer R69 to ground. The i-f component of the current is filtered by capacitors C141 and C142 operating in conjunction with the load resistors. The a-f component of the signal is coupled through capacitor C143 to the a-f amplifier circuits. The "DIODE OUTPUT" terminals provide a convenient connection point for d-c-operated recording equipment. Also, when the jumper is removed and the negative terminal interconnected to a second receiver in a space-diversity receiving system, the second receiver provides the composite audio output signal.

4-49. When "AVC/MAN" switch S8 is set to the "AVC" position, the voltage developed across potentiometer R69 in the detector circuit is applied to tuning meter M1 through "METER" switch S11. Meter M1 has a d-c movement and responds to the d-c voltage developed across potentiometer R69. The d-c voltage is proportional to the input signal level and meter M1 is calibrated to indicate input signal level in db. Potentiometer R69 is adjusted for zero db indication on meter M1 with an input signal of one microvolt applied to the antenna input circuit.

4-50. When "LIMITER/OFF" switch S6 is set to the "LIMITER" position, the shunt noise-limiter circuit reduces pulse-type noise interference in the receiver output. The plate of noise-limiter tube V15A is connected through a long time-constant filter, comprising capacitor C144 and resistor R67, to the junction of resistors R62 and R63 in the detector load network. Since capacitor C144 cannot charge and discharge rapidly enough through resistor R67 to follow rapid voltage fluctuations, the filter maintains the plate voltage of the tube constant at the average d-c level at the junction of resistors R62 and R63. The cathode of tube V15A is connected directly to the junction of resistor R63 and capacitor C142 and the cathode voltage varies directly with any voltage fluctuations at the junction point. In the absence of a noise pulse, the plate of diode V15A is negative with respect to its cathode and the tube does not conduct. When a sharp noise pulse is applied to the detector circuit, it is detected and the current through the load network momentarily increases; the cathode voltage of tube V15A becomes more negative but the plate voltage does not change, due to the long time constant of the filter; the cathode of V15A becomes negative with respect to the plate; and tube V15A conducts and shunts the detector load current to ground through the low-impedance

path provided by the tube and capacitor C144. The signal applied to the a-f amplifiers is momentarily interrupted and the noise pulse does not appear in the receiver output.

4-51. For maximum weak-signal sensitivity, a delayed a-v-c system is used in the receiver. The cathode of a-v-c rectifier tube V14B is connected to a voltage divider comprising resistors R66 and R68 across the regulated +150-volt supply. Initially, the cathode of the tube is approximately 23 volts positive with respect to the plate, the tube does not conduct, and the initial bias level applied to the controlled tubes is established by "RF GAIN" control R93. The initial bias voltage is applied from the "RF GAIN" control through resistor R97 and "AVC/MAN" switch S8 to the circuits of tubes V6, V7, V9, and V10 and through a voltage divider comprising resistors R48, R115, R116, and R94 to the circuits of tubes V1 and V2. Resistor R97 isolates the plate of a-v-c rectifier tube V14B from the negative voltage applied by the "RF GAIN" control. When a 455-kc signal of sufficient amplitude is applied through capacitor C138 to the a-v-c rectifier circuit, the plate of tube V14B becomes positive with respect to the cathode on the positive signal excursions; tube V14B conducts and rectifies the incoming signal; and a negative d-c voltage which is proportional to the carrier level is developed across resistor R61. The i-f and a-f components of the rectified voltage are removed by a filter circuit, comprising capacitors C140, C164, and C169 and resistors R60 and R111, and the resultant d-c voltage is applied through "AVC/MAN" switch S8 to the bias network for tubes V1, V2, V6, V7, V9, and 10. The "AVC" terminals on the rear apron provide the means for interconnecting two receivers in a space-diversity system. When "MOD/CW" switch S7 is actuated to the "CW" position, one section of the switch connects capacitor C137 into the a-v-c filter circuit, the time constant of the circuit is increased, and normal a-v-c operation is possible during the reception of keyed signals. For direction-finding applications, the circuits of tubes V1 and V2 are connected to the DF terminals in the bias supply to increase receiver sensitivity and sharpen receiver selectivity.

4-52. AUDIO SECTION. (See figure 4-10.) The audio section of the receiver comprises a two-stage a-f amplifier and a meter rectifier circuit. The two-stage a-f amplifier provides a maximum undistorted audio output of two watts, available at the "AUDIO OUTPUT" terminals on the rear apron of the receiver. The meter rectifier circuit provides the means for measuring the audio power supplied from the "AUDIO OUTPUT" terminals to a 600-ohm load.

4-53. The a-f voltage developed in the second detector circuit is coupled to the first a-f amplifier stage by means of capacitor C143 and developed across "AUDIO GAIN" control R84. Potentiometer R84 establishes the level of the voltage applied to the grid of tube V16B. The first a-f amplifier stage is a triode, resistance-capacitance-coupled amplifier with bias voltage developed across cathode resistor R83. The output voltage of the stage is

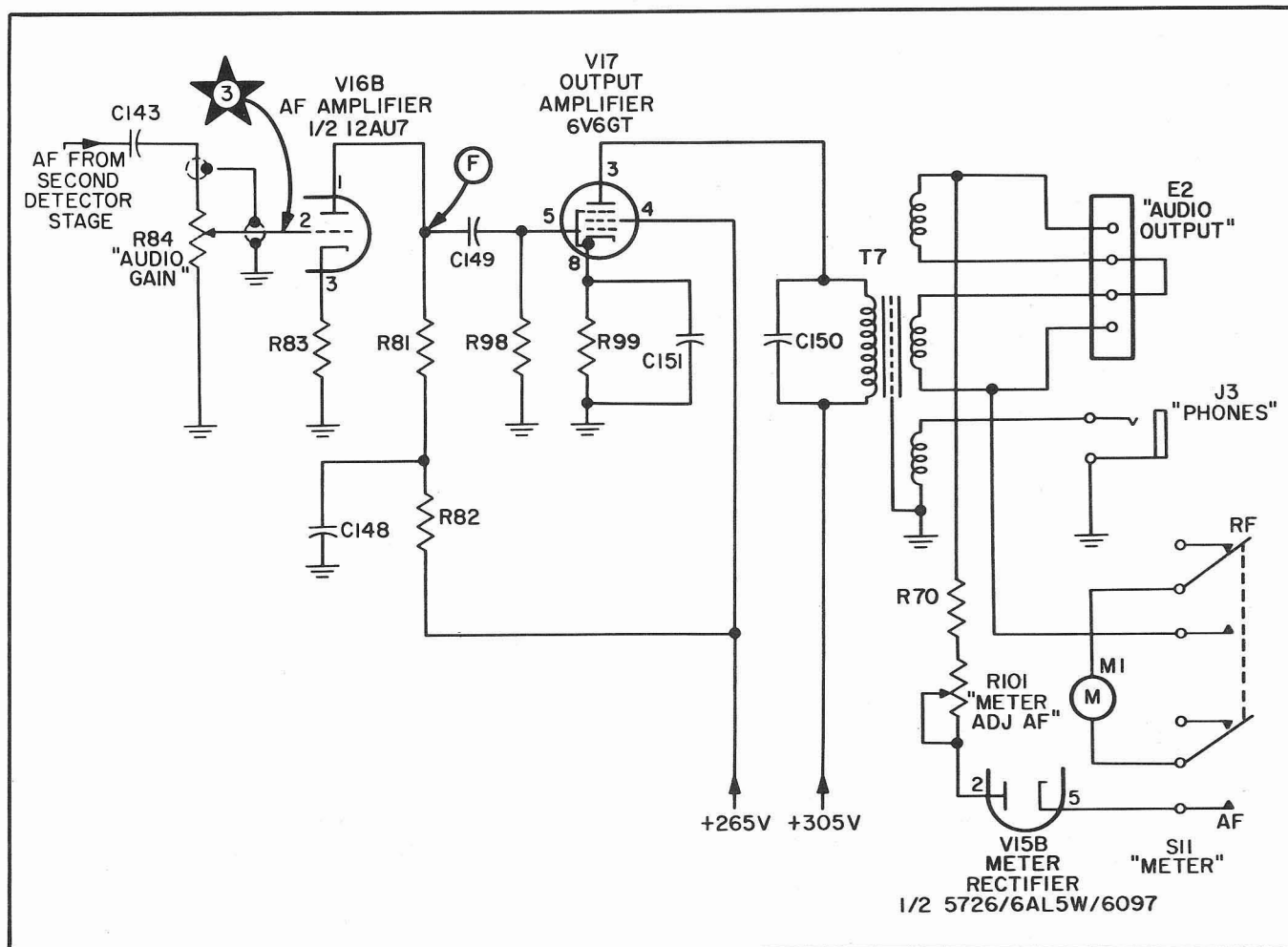

Figure 4-10. Audio Circuits, Schematic Diagram

developed across plate load resistor R81 and coupled to the grid of output amplifier tube V17 by means of capacitor C149 and resistor R98. Resistor R82 and capacitor C148 comprise the plate decoupling network.

4-54. The output amplifier stage utilizes an a-f power amplifier circuit comprising tube V17 and its circuitry. Bias is provided by cathode resistor R99, which is suitably bypassed for af by capacitor C151. Output transformer T7 serves as the plate load and provides the proper impedance match between the load circuits and the plate of the tube. Capacitor C150 is connected across the primary of transformer T7 to bypass spurious high frequencies from the audio output. Transformer T7 has two separate secondary windings. The secondary winding connected to "PHONES" jack J3 provides an attenuated output for application to a headset. The secondary winding connected to the "AUDIO OUTPUT" terminal board is designed to match a 600-ohm load. The 600-ohm secondary is split and the two sections are connected together at the "AUDIO OUTPUT" terminal board. When a 600-ohm transmission line carries the

audio output to a remote operating point, a d-c device such as a teletypewriter may share the same transmission line. The d-c output current of the teletypewriter is applied between the junction of the two sections of the split secondary winding and ground. Since the sections are balanced, the fields produced by the d-c current cancel in transformer T7 and in no way interfere with the normal audio output of the receiver.

4-55. The meter rectifier circuit comprises tube V15B and its circuitry, connected across the 600-ohm secondary winding of output transformer T7. The audio output voltage developed across the secondary winding of transformer T7 is rectified by tube V15B and applied to tuning meter M1 when the "METER" switch is held in its "AF" position. Meter M1 contains a 0-to-200-microampere movement and the meter rectifier circuit arrangement is similar to that of an a-c voltmeter. Resistor R70 is the meter multiplier resistor and potentiometer R101 provides the means for accurately calibrating the meter. The scale of meter M1 is calibrated in db, with zero db corresponding to a standard of six milliwatts across 600 ohms.

4-56. POWER SUPPLY. The simplified schematic diagram of the power supply is shown in figure 4-11. Two separate rectifier systems are used: a B-rectifier and a C-rectifier. The B-rectifier uses a full-wave rectifier tube, a two-section pi-type filter, and a voltage regulator circuit and furnishes regulated voltages to the critical circuits of the receiver (i.e., the a-v-c delay circuit, the various oscillator circuits, etc) and unregulated voltages to the plate and screen circuits of the remaining tubes in the receiver. The C-rectifier system comprises a full-wave rectifier tube, a three-section L-type filter, and a voltage-divider network. The C-rectifier system furnishes bias voltages to the various i-f and r-f amplifier tubes in the receiver, either through a fixed voltage divider or through the variable "RF GAIN" control. The power-supply section is protected by fuses in the primary and secondary circuits of the power transformer.

4-57. When power switch S10, part of the "RF GAIN" control assembly, is actuated, power is applied to the primary of power transformer T8 through "LINE" fuse F1. The primary of transformer T8 is tapped to provide for input voltages within the range of 90 to 270 volts. A-c power outlet J5 is connected directly across the a-c line and may be used for operating an accessory such as an electric clock or lamp. Capacitors C152 and C168 bypass to ground noise interference introduced through the a-c power system.

4-58. B-rectifier tube V19 obtains its plate voltage from the high-voltage secondary winding of transformer T8 and its filament voltage from the 5-volt secondary winding. The applied voltage is rectified and applied to a

two-section, pi-type filter comprising capacitors C161A, C161B, and C161C and filter chokes L51 and L52. Voltage regulator tube V18 is connected to the output of the B-rectifier circuit through dropping resistor R85 and furnishes regulated +150 volts. The B-rectifier system also furnishes unregulated voltages of +305 volts and +265 volts maximum.

4-59. The C-rectifier system utilizes the same high-voltage secondary winding of transformer T8; however, the voltage is reduced through divider networks comprising resistors R86, R87, R88, and R89 before application to rectifier tube V20. The rectified output of tube V20 is filtered by resistors R90, R91, and R92 and capacitors C158, C159, and C160, arranged in a three-section, L-type filter. Resistors R95, R96 and R94 and potentiometer R93 comprise voltage divider networks to provide suitable bias voltages to the receiver tubes. The voltage at the junction of resistors R95 and R96 is -10 volts while potentiometer R93, the "RF GAIN" control, provides voltages within the range of -1 to -51 volts.

4-60. Power transformer T8 also furnishes filament voltages for the receiver tubes. The two 7.5-volt secondary windings furnish filament voltages to the tubes in the r-f section of the receiver. R-f filters comprising inductor L48 and capacitor C153, inductor L49 and capacitor C155, and inductor L50 and capacitors C156 and C157 filter r-f interference from the filament circuits involved. The 6.3-volt secondary winding of transformer T8 supplies power to pilot lights I1, I2, I3, and I4 and filament voltage to the filaments of the remaining tubes in the receiver.

SECTION V

ORGANIZATIONAL MAINTENANCE

5-1. GENERAL.

5-2. This section contains instructions for maintenance of the radio receiver at the organizational level. Receiver performance tests, trouble analysis, repair, alignment, and preventive maintenance procedures are included.

5-3. RECEIVER PERFORMANCE TESTS.

5-4. PRELIMINARY RECEIVER CHECKS. To minimize delays due to receiver defects, the following checks of receiver operation should be performed before performance tests are attempted:

a. Check to see that the loudspeaker is connected across "AUDIO OUTPUT" terminals (8, figure 1-3) and that the headset is plugged into "PHONES" jack (20, figure 1-2).

b. Turn the power on and note that the pilot lamps light; if not, replace 1.6-ampere "LINE" fuse (11, figure 1-3).

c. Note that all glass-enclosed electron tube filaments light and that voltage regulator tube V18 shows a faint violet glow; if not, replace each defective tube.

d. Tune in first an A-M signal and then a c-w signal on each band and check the operating controls for each mode of operation. Check the mechanical performance

of each control for tightness, switch action, and indentation, as applicable. Check "RF GAIN" control (12, figure 1-2) and "AUDIO GAIN" control (16) for noisy operation.

e. If any defect is discovered during the preliminary check, the receiver must be serviced before the performance tests can be performed. If the required service is beyond the scope of organizational maintenance activities, tag the receiver, indicating the nature of the defect, and initiate the necessary action for field maintenance.

5-5. PERFORMANCE TEST PROCEDURE. If the receiver operates normally during the preliminary checks outlined in paragraph 5-4, proceed with the receiver performance tests outlined in table IX. If the receiver fails to meet any of the minimum performance standards noted in the table, refer to paragraphs 5-8 through 5-18 for corrective maintenance instructions.

5-6. TROUBLE ANALYSIS.

5-7. GENERAL. In instances where the receiver fails to meet a minimum performance standard, the performance test involved generally serves to localize the defect to a specific functional section of the receiver. The defect may be further isolated through use of a test-point analysis of the defective section of the receiver.

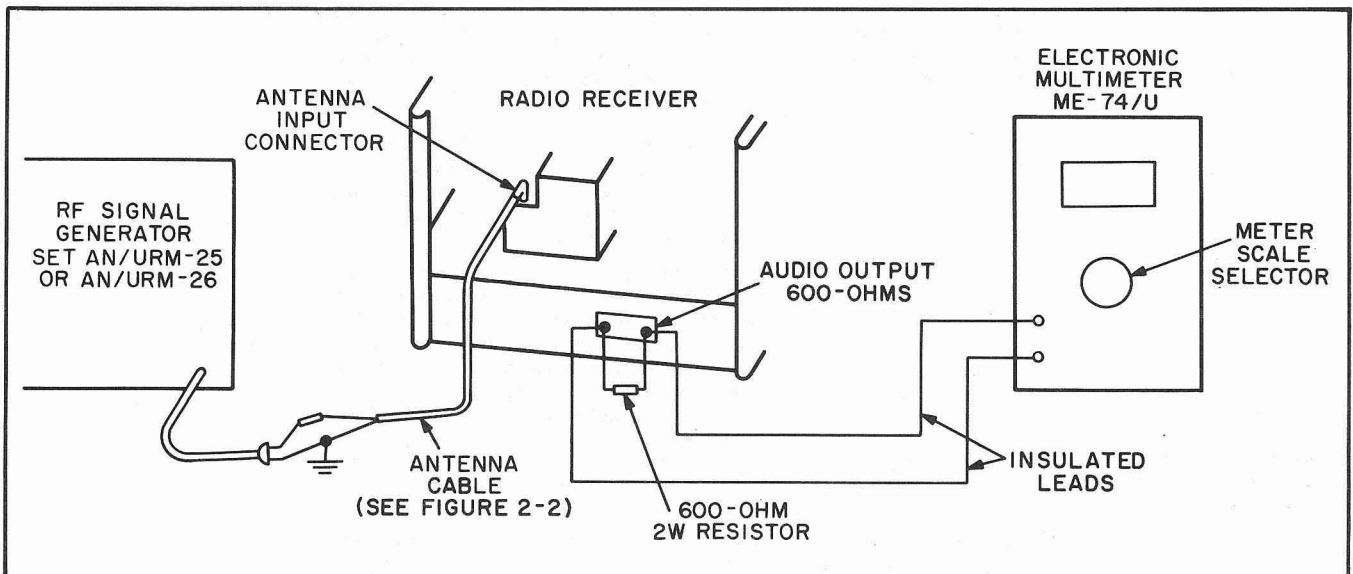

Figure 5-1. Receiver Sensitivity Test Setup

TABLE IX. RECEIVER PERFORMANCE TESTS

Test	Control Settings	Procedure and Minimum Performance Standard Requirements	Possible Source of Trouble
Receiver Sensitivity (10:1 signal plus noise-to-noise power ratio)	<p>Set signal generator to any frequency within range of receiver.</p> <p>Set signal generator for an A-M, 400-cycle, 30-percent-modulated signal at an output level of approx 3 uv.</p> <p>Set receiver for m-c-w reception with "RF GAIN" control fully clockwise, "AVC/MAN" switch to "MAN", "SELECTIVITY" switch to "3 NON-XTAL", "MOD/CW" switch to "MOD".</p> <p>Turn modulation selector on signal generator to off.</p> <p>Restore modulation selector to 400-cycle position.</p>	<p>Connect equipment as shown in figure 5-1.</p> <p>Tune receiver to signal generator frequency. Adjust "AUDIO GAIN" control to obtain a reading of 10 db on electronic multimeter. (This is a power output of 10 mw from receiver since 1 mw across 600 ohms is zero db level of electronic multimeter.)</p> <p>Note db reading on electronic multimeter.</p> <p>Adjust r-f output control on signal generator to obtain a reading 10 db higher than that obtained when modulation selector was in off position.</p> <p>Note r-f uv output reading on signal generator. A reading of 2 uv or less at any signal frequency within tuning range of receiver is required under minimum performance standards.</p> <p>Adjust "AUDIO GAIN" control for a reading of 10 db (10-mw output) at 10:1 point and record exact setting of control.</p>	<p>I-f section: V9, V10, V11, T2, T3, T4, and/or T5 with regard to gain</p> <p>R-f section: V1, V2, and/or any one of r-f tuner subassemblies for band involved with regard to signal plus noise-to-noise ratio</p>
Rejection Ratio, 455-kc if	<p>Set signal generator to 600 kc; modulation selector at 400-cycle position, 30-percent modulation.</p> <p>Change signal generator frequency to 455 kc.</p>	<p>(Equipment connected as shown in figure 5-1.)</p> <p>Repeat receiver sensitivity test to obtain signal generator r-f uv output reading required to establish 10-db reference level on electronic multimeter. Record this r-f uv output reading.</p> <p>Keep receiver set at 600 kc and increase signal generator r-f uv output until a reading of 10 db is again obtained on electronic multimeter. Record reading of signal generator r-f uv output.</p> <p>Divide signal generator r-f uv output reading obtained at 600 kc by reading obtained at 455 kc to obtain 455-kc i-f rejection ratio. A voltage ratio of 3000 (69 db) or more is required under minimum performance standards. This rejection ratio must increase for signals above 600 kc and below 7.4 mc.</p>	<p>R-f section: antenna r-f tuner and/or one or both interstage r-f tuners of selected band</p>
Rejection Ratio, 3955-kc if	<p>Set signal generator to 7.6 mc; modulation selector at 400-cycle position, 30-percent modulation.</p>	<p>(Equipment connected as shown in figure 5-1.)</p> <p>Repeat receiver sensitivity test to obtain signal generator r-f uv output reading required to establish 10 db reference level on electronic multimeter. Record r-f uv output reading.</p>	

TABLE IX. RECEIVER PERFORMANCE TESTS (Cont)

Test	Control Settings	Procedure and Minimum Performance Standard Requirements	Possible Source of Trouble
	Change signal generator frequency to 3955 kc.	Keep receiver set to 7.6 mc and increase signal generator r-f uv output until reading of 10 db is again obtained on electronic multimeter. Record r-f uv output reading.	R-f section: antenna r-f tuner and/or one or both interstage r-f tuners of selected band
		Divide signal generator r-f uv output reading obtained at 7.6 mc by reading obtained at 3955 kc to obtain 3955-kc i-f rejection ratio. A voltage ratio of 50,000 (94 db) or more is required under minimum performance standards. This rejection ratio must increase for signals above 7.6 mc and below 54 mc.	
C-W Performance	Set signal generator to any frequency within range of receiver; modulation selector at off.	(Equipment connected as shown in figure 5-1 except that electronic multimeter need not be connected.)	Auxiliary circuit section: tubes V12 and/or V13 and associated circuitry
	Set receiver for c-w reception; "MOD/CW" switch to "CW", "AVC/MAN" switch to "MAN", "BEAT OSC." control to "O".	Tune receiver to signal generator frequency. Vary "BEAT OSC." control either side of its zero position and roughly determine that a 3-kc beat note can be obtained on either side of zero.	
	Set receiver "AVC/MAN" switch to "AVC", "SELECTIVITY" switch to any "XTALS" position.	Connect an audio oscillator to a headset or loudspeaker and, by matching tone output of audio oscillator to beat output of receiver, determine that beat note is 3 kc.	
		Check frequency stability of bfo by setting "BEAT OSC." control to arbitrary settings and noting whether or not beat note remains constant at each setting.	
		Disconnect signal generator and connect antenna to receiver. Tune receiver to a c-w signal and adjust "RF GAIN" control for a suitable output level. Disconnect antenna and reconnect signal generator. Adjust signal generator frequency to a point closely adjacent to receiver setting, as indicated by heterodyne interference in receiver output.	
		Vary receiver "XTAL PHASING" control and determine that heterodyne interference can be attenuated.	
Selectivity	Set signal generator to 2 mc, modulation selector at 400-cycle position, 30-percent modulation.	(Equipment connected as shown in figure 5-1.)	
	Set receiver "SELECTIVITY" switch to "13 NON-XTALS".	Repeat receiver sensitivity test to obtain signal generator r-f uv output reading required to establish 10-db reference level on electronic multimeter.	
		Adjust signal generator output control to obtain 10-db level. Record r-f uv output reading.	Successively increase r-f uv output reading by multiplying by 10, 100, and 1000, each time detuning receiver on either side of resonance while observing electronic multimeter reading. When meter reading drops to 10-db reference level, record receiver deviation, in kc, from resonant point.

TABLE IX. RECEIVER PERFORMANCE TESTS (Cont)

Test	Control Settings	Procedure and Minimum Performance Standard Requirements	Possible Source of Trouble
Selectivity (Cont)	Successively set receiver "SELECTIVITY" switch to each of its other positions.	Repeat above procedure for each position of "SELECTIVITY" switch. Plot, on semi-log graph paper, resonance input, and 10, 100, and 1000 times resonance input, versus receiver deviation. Use logarithmic scale as ordinates for resonance inputs and linear scale as abscissae for receiver deviation. Compare resulting graph with that shown in figure 4-1; it should agree very closely.	I-f section: T2, T3, T4, and/or T5
Rated Power Output	Set signal generator for an A-M, 400-cycle, 30-percent-modulated, 2-uv signal at any frequency within range of receiver. Set receiver "RF GAIN" control to max; "AVC/MAN" switch to "MAN"; "SELECTIVITY" switch to 3-kc setting; "MOD/CW" switch to "MOD".	(Equipment connected as shown in figure 5-1.) Tune receiver to signal generator frequency. Adjust "AUDIO GAIN" control to max and note receiver output level. Receiver output should be 2 watts or more (33 db on Electronic Multimeter ME-74/U) with a 2-uv input signal.	A-f section: V16B, V17, T7
Rated I-f Output	Adjust signal generator and receiver controls same as for rated power output test.	Connect equipment as shown in figure 5-2. Tune receiver to signal generator frequency. Note receiver i-f output indication on electronic multimeter. Receiver i-f output should be 200 mv or more with a 2-uv input signal.	I-f section: V16A
Image Rejection Ratio		Connect equipment as shown in figure 5-1. Measure receiver sensitivity at signal frequencies listed in table IV, following procedure outlined above for receiver sensitivity test. Record input signal voltage required for 10-mw output at each frequency listed. On receiver band 1, set signal generator to a frequency 910 kc higher than frequency listed in table IV. With receiver tuned to frequency listed in table IV and with all controls adjusted as for sensitivity test, increase signal generator input level until receiver output again measures 10 mw. Note and record input signal level required to produce this output. Repeat procedure for receiver bands 2 and 3, in turn, using signal generator frequencies 910 kc higher than signal frequencies listed in table IV. Repeat procedure for bands 4, 5, and 6 except set signal generator frequencies 7910 kc higher than frequencies listed in table IV. Calculate image rejection voltage ratio for each frequency listed by dividing input voltage required at image frequency by voltage required at signal frequency to produce a 10-mw output level in each instance. Image rejection ratios calculated should approximate those listed in table IV.	R-f section: antenna r-f tuner or interstage r-f tuner subassemblies of band concerned

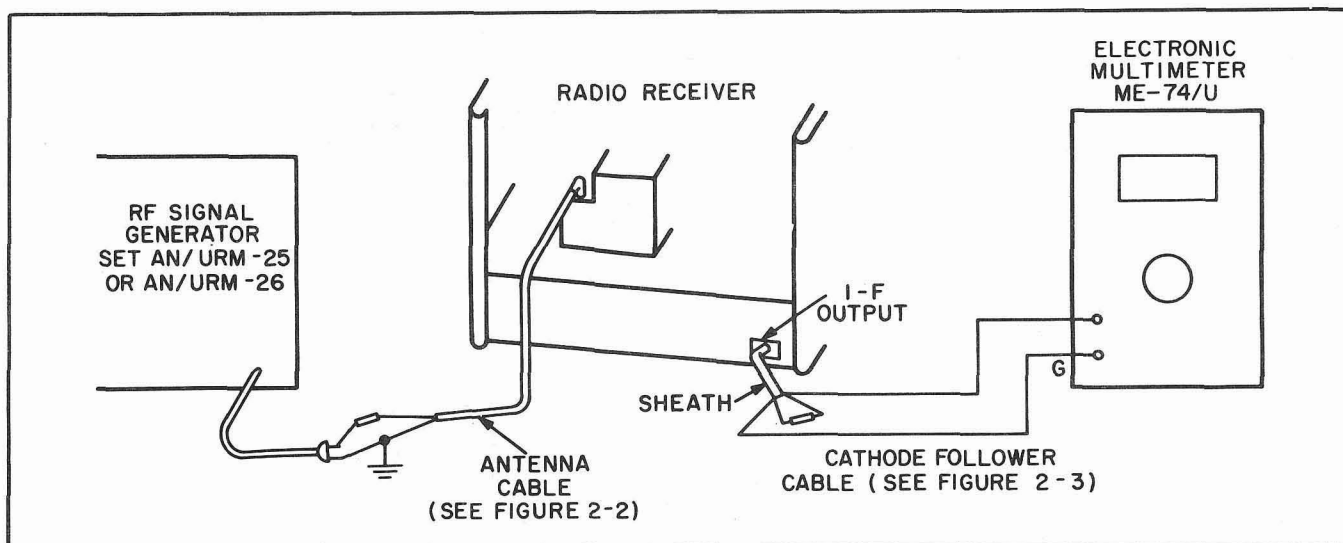

Figure 5-2. Receiver Cathode-follower Test Setup

TABLE X. POWER SUPPLY TEST-POINT DATA





Step	Test Point	Test-Point Indication	Receiver Adjustments	Possible Cause of Abnormal Indication
1	 Junction of L51, L52, and C161B	+280V	"RF GAIN" control at max	F2, V19, V17, T7
		+350V	"RF GAIN" control at min	
			Set "FREQ CONTROL" selector switch to "VFO".	If fault clears, check V3.
			Set "SEND/REC" switch to "SEND".	If fault clears, check V1, V2, V6, V7, V8.
		Set "SEND/REC" switch to "REC"; rotate "BAND CHANGE" control through six bands.	If fault is present only on bands 4, 5, and 6 check V6, V8, and T9; if fault is present only on bands 1, 2, and 3, check V7.	
2	 Junction of C161C, L52, and R82	+228V	"RF GAIN" control at max	If indication in step 1 is normal but step 2 is abnormal, check L52.
		+265V	"RF GAIN" control at min	
3	 Pin 1 of V18	+150V	Set "FREQ CONTROL" selector switch to "VFO" and then to "XTALS" positions.	If indications in steps 1 and 2 are normal but step 3 is abnormal, check V18. If trouble clears in "VFO", check V3; if fault clears in "XTALS", check V4.
4	 Junction of R72 and R73	+90V	"RF GAIN" control at max	V10, V9
		+150V	"RF GAIN" control at min	
5	 Junction of C160, R92, and R93	-51V	None	V20, V10, V9, V7, V6, T2

TABLE X. POWER SUPPLY TEST-POINT DATA (Cont)

Step	Test Point	Test-Point Indication	Receiver Adjustments	Possible Cause of Abnormal Indication
6	(D) Junction of R95 and R96	-10V	None	Field maintenance required.
7	(E) Junction of R93 and R94	-1V	"MAN/AVC" switch at "MAN"; "RF GAIN" control at max	V10, V9, V7, V6, T2

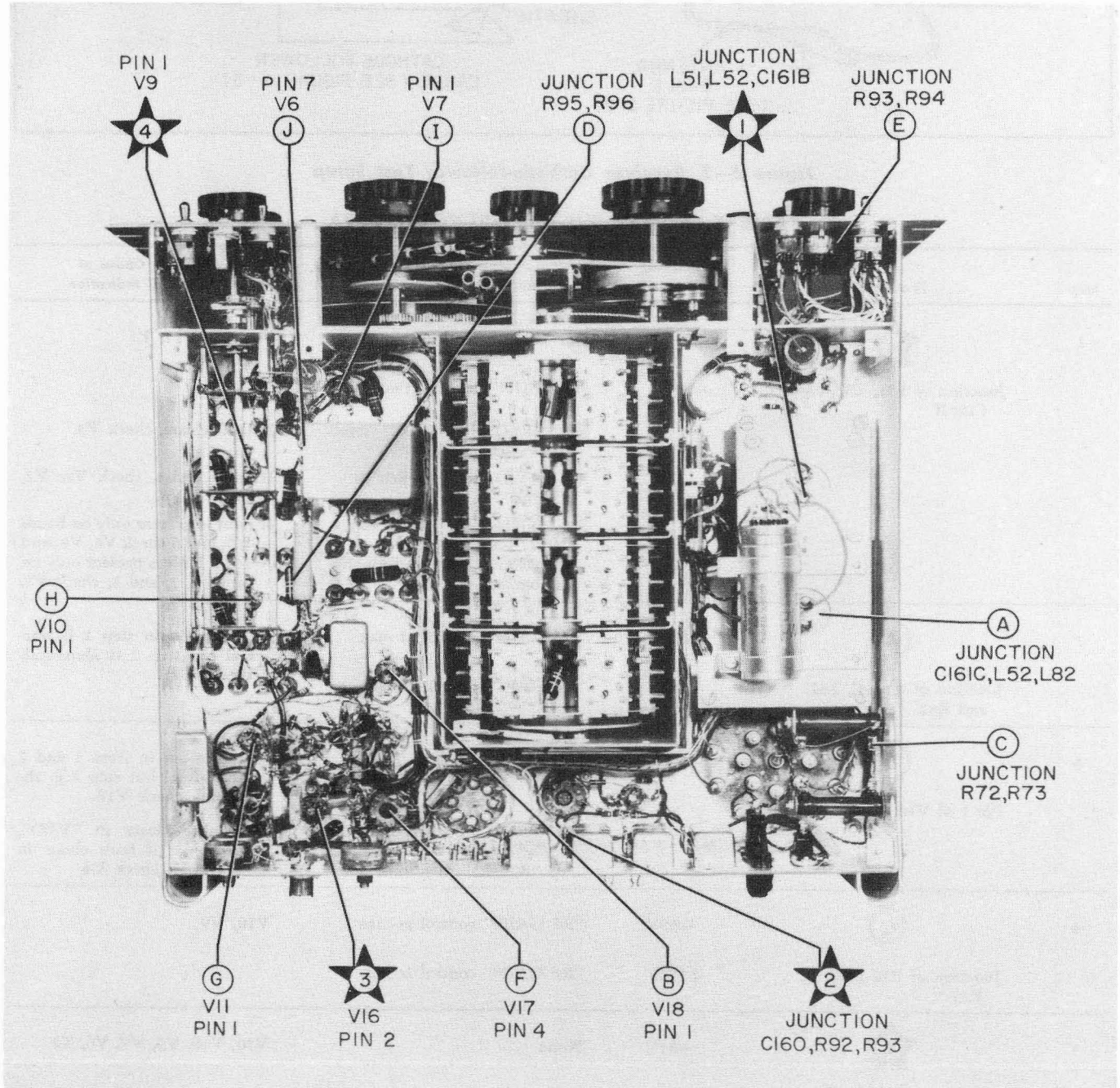

Figure 5-3. Radio Receiver Test-point Location

5-8. **TEST-POINT ANALYSIS.** A step-by-step procedure using receiver test points for isolation of receiver defects is outlined in table X and table XI. The possible causes of abnormal indication are limited to electron tubes and subassemblies designed for easy removal. If replacement of electron tubes or the subassemblies listed does not restore the receiver to normal operation, the receiver requires field maintenance. In the tables, major test points identified by Arabic numerals enclosed in stars are used to localize defects to a specific section of the receiver; i.e., power supply, audio, if., etc. Secondary test points identified by encircled capital letters are used to isolate the defect to a single stage or group of stages, or to a subassembly.

5-9. To perform the test-point checks in table X, remove the receiver bottom plate and identify each test point from the parts identification provided in figure 5-3. Then turn the power on and use a vtvm or a 20,000-ohm-per-volt d-c voltmeter to measure the d-c voltage between each test point and the receiver chassis ground. When abnormal indications are obtained, replace the electron tubes listed in the table and repeat the test. If the trouble persists, refer to table XI.

5-10. Table XI lists additional test-point checks which are useful in isolating defects, particularly those due to defective receiver subassemblies. The test points used for the checks in table XI can be identified from the parts identification provided in figures 5-3 and 5-4; each test point listed, with the exception of test points 5 and 6, is accessible from the bottom of the receiver when the bottom plate is removed. Use a miniature tube adapter to gain access to test point 5. Test point 6 is the antenna input connector (J1, figure 5-4). To check the test-point indications, turn the power on and use an a-c vtvm to measure the signal voltages from the test points to ground.

Note

For accurate voltage indications, the fungicidal varnish at a solder joint must be pierced to make positive electrical contact.

5-11. MINOR REPAIR AND REPLACEMENT.

5-12. **TUBES.** (See figure 5-4.) To replace tubes V17 or V19, the top-hat-type tube clamp must first be removed. Remove the clamp by pressing inward on the top-hat spring while lifting the clamp off the tube. Lift the tube out and replace. To replace the clamp, seat it on top of the tube and thread the vertical bolt adjacent to it through the hole in the top-hat spring, using a ratchet motion. To replace tube V4, loosen the knurled screw which holds the tube shield rigid and remove the shield by turning counterclockwise while exerting downward pressure. Remove the tube with a tube remover and replace. Replace the tube shield and tighten the knurled screw. To replace any of the remaining tubes in the receiver, first remove the tube shield by twisting it counterclockwise while exerting downward pressure. Then lift out the tube with a tube remover and replace it. Replace the tube shield.

5-13. **PILOT LAMPS.** The four pilot lamps used in the receiver are of the bayonet-base type. To remove a pilot lamp, lift the individual lamp socket off its support, twist the pilot lamp counterclockwise in the socket while exerting inward pressure, and lift out the pilot lamp. To insert a replacement pilot lamp in the socket, follow the reverse procedure. Replace the socket on its support.

5-14. **FUSES.** To replace the 1.6-ampere or $\frac{3}{8}$ -ampere fuse located in the fuseholders on the rear apron of the receiver, press in the top of the fuseholder while turning it approximately 45 degrees in a counterclockwise direction. Remove the pressure and pull the cap of the fuseholder, to which the fuse is spring-clamped. Replace with a spare fuse of the correct rating by following the reverse procedure.

CAUTION









Replace fuses with fuses of the correct rating. Use of fuses with higher current ratings will result in damage to the receiver.

5-15. **CRYSTALS.** To replace a defective crystal, loosen the knurled thumbscrew on top of the crystal holder, push the retainer spring assembly to the rear, and remove the crystal from its socket. Insert the replacement crystal in the same crystal socket, bring the retainer spring assembly forward so that the springs press down on the crystals contained in the crystal holder, and tighten the thumbscrew. Always insert the replacement crystal into the crystal socket which carried the removed crystal, so that the plastic chart (9, figure 1-2) and "FREQ CONTROL" selector switch (8) numerical designations correspond to that of the crystal socket. If for any reason a crystal of a different frequency is inserted in the socket, or a crystal is moved to another socket, make appropriate corrections to the figures recorded on the plastic chart, using pencil or ink.

5-16. REMOVAL AND REPLACEMENT OF SUBASSEMBLIES.

5-17. **R-F TUNER SUBASSEMBLY.** To remove any one of the four r-f tuner subassemblies for a specific frequency band, rotate the "BAND CHANGE" control (17, figure 1-2) so that the defective r-f tuner subassembly is positioned in the opening provided when the tuning unit bottom shield is removed. Each coil assembly is held in place by two flat springs, one at either end of the isolantite base forming part of the r-f tuner subassembly. To remove a flat spring, grasp it with the special pliers (see figure 2-1) at its inward full-length edge, press downward, and pull inward with a circular motion until it comes free. Do the same for the other flat spring and lift out the r-f tuner subassembly. To replace an r-f tuner subassembly, follow the reverse procedure. When replacing an r-f tuner subassembly, make certain that the replacement subassembly is identical to the subassembly removed.

TABLE XI. RECEIVER SECTIONS TEST-POINT DATA

Step	Test Point	Test Equipment Control Position	Receiver Adjustments	Normal Indication	Possible Cause of Abnormal Indication
1	 Pin 5, V17	Apply 400-cps audio signal between test point and ground. Couple signal to test point thru 0.01-uf capacitor. Adjust signal gen to provide 20-V rec output to 600-ohm resistive load across rec "AUDIO OUTPUT" term.	"AUDIO GAIN" control at max	Input from signal gen approx 5.5V	V17 and/or T7
2	 Pin 2, V16 section B	Same as step 1	Same as step 1	Input from signal gen approx 0.5V	V16B
3	 Pin 1, V11	Apply 455-kc signal, 400-cps AM, of 30 percent, thru 0.01 uf, between test point and ground. Adjust signal gen to provide 20-V rec output to 600-ohm resistive load across rec "AUDIO OUTPUT" term.	Rec switched for mcw, "AUDIO GAIN" control at max, and "LIMITER/OFF" switch in "OFF" position	Input from signal gen approx 0.6V	V11, V14, and/or V15
4	 Pin 1, V10	Same as step 3	Same as step 3; also "RF GAIN" control at max, "AVC/MAN" switch in "MAN" position, and "BAND CHANGE" control set for 1.35—3.45 mc	Input from signal gen approx 15,000 uv	V16A, V10 and/or T5
5	 Pin 1, V9	Same as step 3	Same as step 4	Input from signal gen approx 300 uv	V9 and/or T4
6	 Pin 1, V7	Same as step 3	Same as step 4	Input from signal gen approx 75 uv	V6, V7, and/or T3
7	 Pin 7, V5	Same as step 3	Same as step 4	Input from signal gen approx 90 uv	V5 and/or T2
8	 Pin 7, V6	Apply 3955-kc signal, 400-cps AM, of 30 percent, thru 0.01 uf, between test point and ground. Adjust signal gen to provide 20-V rec output to 600-ohm resistive load across rec "AUDIO OUTPUT" term.	Same as step 4 but "BAND CHANGE" control set for 7.40-14.8 mc	Input from signal gen approx 100 uv	V6, V7, and/or V8; 3.5-mc crystal hetrodyne subassembly
9	 Rec antenna input	Connect equipment as shown in figure 5-1. Repeat sensitivity-test adjustments, choosing signal for any rec freq band or rec freq band with abnormal indication.	Same as for sensitivity test (refer to table IX)	Input from signal gen 2 uv, or less	V1, V2, and/or V3 for fixed freq operation and/or V4 for var freq operation; any of r-f tuners for freq band concerned

CAUTION

Make certain that the r-f tuner subassembly is firmly seated and secured by its retaining springs before turning the "BAND CHANGE" control. Failure to observe this precaution may result in damage to the spring contacts of the control.

5-18. I-F TRANSFORMER AND 3.5-MC CRYSTAL HETERODYNE SUBASSEMBLIES. To remove trans-

formers T2, T3, T4, and T5 or the 3.5-mc crystal heterodyne subassembly (see figures 5-3 and 5-4), first remove the shield can by removing the four No. 6-32 machine screws which hold the shield can in place. Then unsolder the externally connected leads at the subassembly terminals and remove the two No. 6-32 machine screws which attach the subassembly to the receiver chassis; lift the subassembly from the receiver. To replace any of the subassemblies, follow the reverse procedure. Make certain that the replacement subassembly is identical to the removed subassembly.

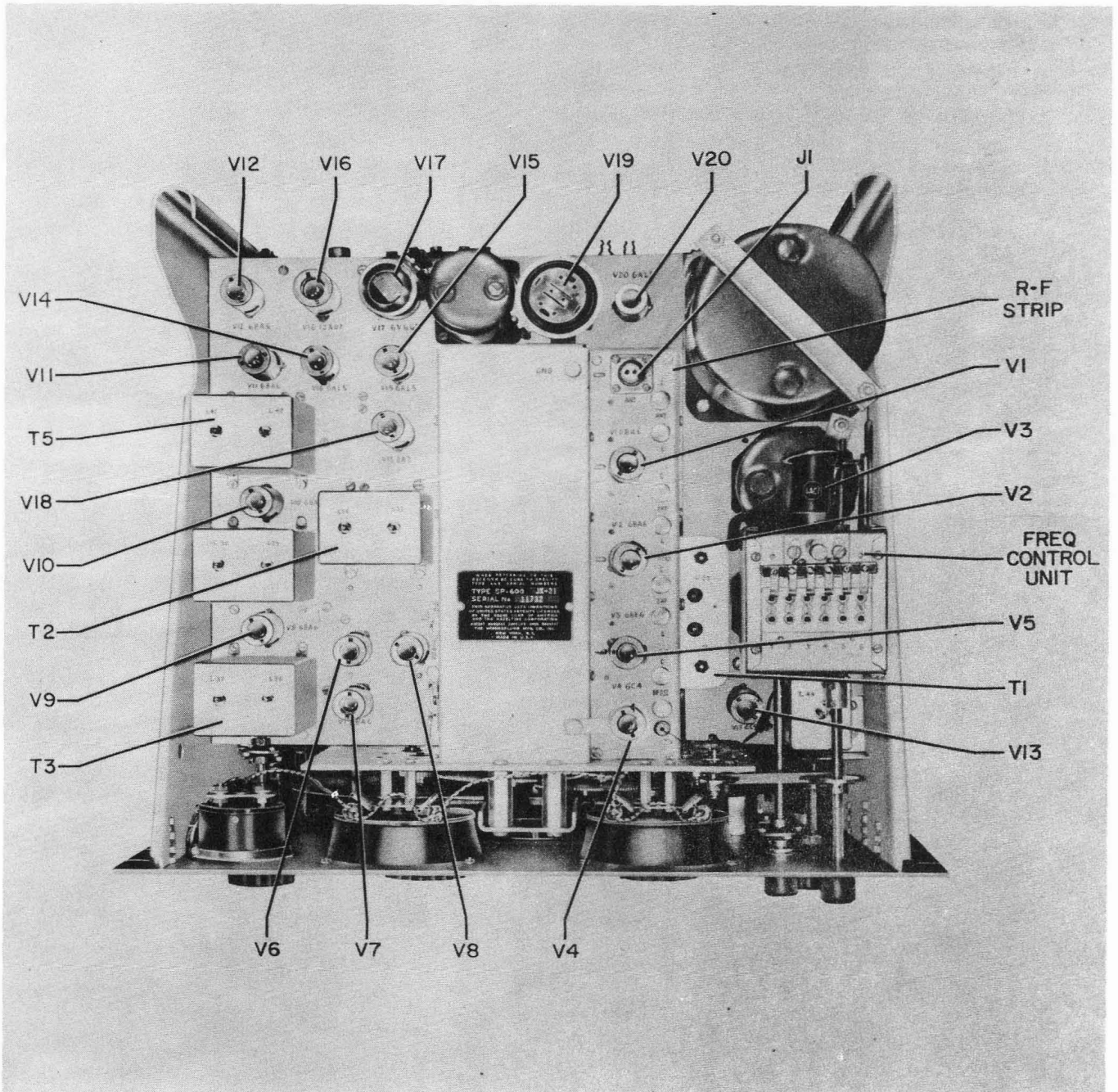

Figure 5-4. Radio Receiver, Top View of Chassis

5-19. ALIGNMENT AND ADJUSTMENT.

5-20. VARIABLE-FREQUENCY HETERODYNE OSCILLATOR ALIGNMENT. Normally, the radio receiver does not require alignment after tube replacement; however, when V4 (see figure 5-4), the variable-frequency heterodyne oscillator tube, is replaced, check the main dial calibration, especially at the high end of each frequency band, by tuning in stations of known frequency. If the calibration accuracy is not 0.25 percent of frequency, or better, over the frequency range of the receiver, realign the variable-frequency heterodyne oscillator only, as follows:

- a. Set up the equipment for the sensitivity test (refer to table IX), with the receiver main dial set, in turn, to the alignment frequencies listed in table XII.
- b. Remove the metal button to align C for the variable-frequency heterodyne oscillator (see figure 5-5). Readjust the capacitor setting slightly with an insulated alignment tool to obtain maximum receiver output.
- c. Remove the metal button to align L for the variable-frequency heterodyne oscillator (see figure 5-5). Readjust the alignment control with an insulated alignment tool to provide maximum receiver output.

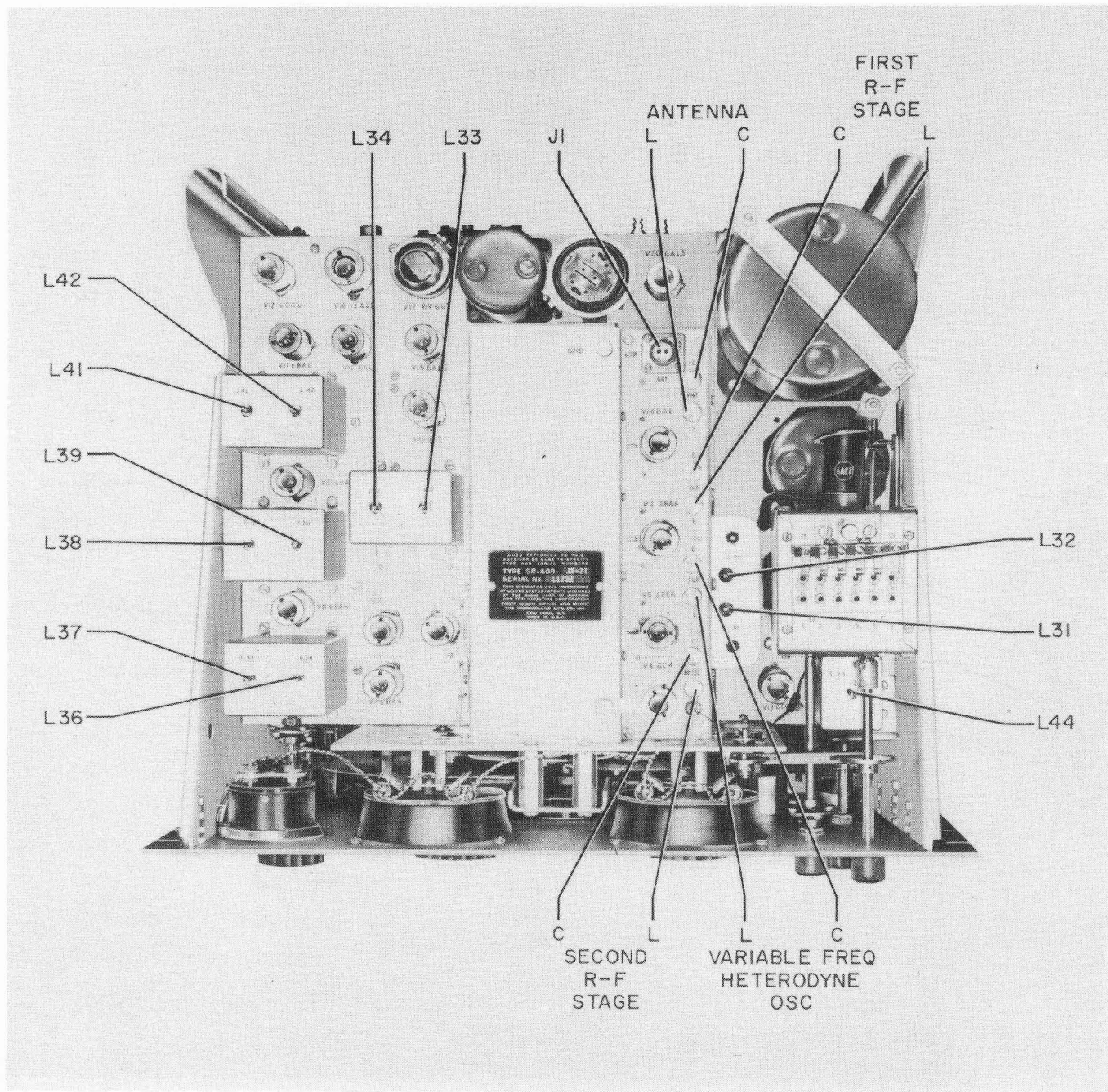

Figure 5-5. Radio Receiver Alignment Adjustments

TABLE XII. ALIGNMENT FREQUENCY AND ADJUSTMENT DESIGNATIONS

<i>Frequency Band (In Mc)</i>	<i>Adjust L At</i>	<i>Adjust C At</i>
0.54— 1.35	0.56	1.30
1.35— 3.45	1.40	3.40
3.45— 7.40	3.75	7.15
7.40—14.80	7.50	14.50
14.80—29.70	15.00	29.00
29.70—54.00	30.00	52.00

d. Repeat steps b and c until no further increase in receiver output is obtained. Note that the receiver output remains at maximum as the alignment tool is withdrawn. Replace the metal buttons.

5-21. R-F TUNER ALIGNMENT. When one or more of the four r-f tuner subassemblies on any frequency band of the receiver is replaced, realign the r-f tuner subassembly concerned.

a. Set up the equipment for the sensitivity test in accordance with table IX and remove the metal buttons that cover L and C for the antenna, the first r-f stage, the second r-f stage, or the variable frequency heterodyne oscillator tuner subassemblies, as applicable. (See figure 5-5.)

b. Align, in turn, L and C for the band concerned, at the receiver alignment frequency shown in table XII, for maximum receiver output, repeating the procedure until no further increase in output results. Replace the metal buttons.

5-22. I-F TRANSFORMER ALIGNMENT. When one or more of the i-f transformers is replaced, realign the corresponding i-f stage of the receiver in the following manner:

a. Set up the equipment for the sensitivity test in accordance with table IX, and locate the applicable i-f transformer tuning cores: L41 and L42 for T5; L38 and L39 for T4; L37 and L36 for T3; and L34 and L33 for T2. (See figure 5-5.)

b. Align, in turn, the adjustable tuning cores for the replaced i-f transformers only, for maximum receiver output, repeating the procedure until no further increase in output results.

5-23. PREVENTIVE MAINTENANCE.

5-24. LUBRICATION. All parts of the radio receiver requiring lubrication have been adequately lubricated at the factory. In normal use, no lubrication within the scope of organizational maintenance activities is required. All spare parts, also, are factory lubricated so that they may be installed without the necessity for lubrication.

5-25. INSPECTION. Table XIII lists the inspection schedule for the radio receiver. The inspections specified should be performed periodically as outlined in the table.

TABLE XIII. INSPECTION SCHEDULE

<i>Component or Part</i>	<i>Procedure</i>	<i>Period</i>
Receiver, receiver windows, headset, cables, antenna system, auxiliary equipment	Inspect all components and make certain they are clean and dry.	Every 25 hr
Fuses, tubes, dial lamps, frequency control unit crystals, r-f tuner subassemblies	Check for proper seating.	Every 25 hr
Interconnecting cables and leads	Check and tighten connections as required.	Every 25 hr
Operating controls	Inspect for signs of looseness, scraping, and binding.	Every 25 hr
Gear train	Check for wear and misaligned or chipped gears.	Every 25 hr

CAUTION

Disconnect a-c power source from receiver before making any of the following checks.

Exposed metal surfaces of receiver, connectors, etc	Check for signs of corrosion.	Every 175 hr
Internal wiring and external cables	Inspect for fraying, cuts, deterioration, and strain.	Every 175 hr

TABLE XIII. INSPECTION SCHEDULE (Cont)

<i>Component or Part</i>	<i>Procedure</i>	<i>Period</i>
Interior surfaces of receiver windows and dials	Check for dirt and moisture.	Every 175 hr
Tuning meter	Inspect meter case and glass for signs of damage. Zero meter with adjustment screw.	Every 175 hr
Tubes and tube sockets	Inspect tubes for loose envelope. Check tube sockets for cracks and broken pins; check sockets for spring tension; check for dirt, moisture, and signs of overheating.	Every 750 hr
Container-enclosed fixed capacitors	Inspect for bulges, leaks and signs of overheating.	Every 750 hr
Variable air capacitors	Check for dirt, moisture and bent or damaged plates.	Every 750 hr
Resistors, bushings, and insulators	Inspect for cracks, chipping, and dirt or moisture. Inspect resistors for signs of overheating.	Every 750 hr
Terminals of wirewound resistors and container-enclosed capacitors	Check for loose connections and loose or broken lugs.	Every 750 hr
Switches, transformers, chokes, potentiometers, terminal boards	Check for loose mountings.	Every 750 hr
"BAND CHANGE" control	Inspect for bent or broken "V" contacts.	Every 750 hr
Terminal boards	Check for loose terminals, cracks, and breaks.	Every 750 hr
Power transformer and audio output transformer	Inspect for loose mounting and signs of overheating.	Every 750 hr

SECTION VI

FIELD MAINTENANCE

6-1. TROUBLE ANALYSIS.

6-2. GENERAL. When a receiver is returned for field maintenance, check the tag for symptoms of the receiver defect. The symptoms listed on the tag often serve to isolate the trouble to a specific section of the receiver, and thus simplify maintenance. If the receiver is only partly disabled, a quick check of its operation in the various possible operating modes may help to isolate the trouble. Note particularly the operation and indication of the meter and all front-panel controls. If these methods fail to isolate the trouble, a systematic troubleshooting procedure is the most expeditious means of locating a defective part. The signal-injection method of troubleshooting is recommended.

6-3. TEST-POINT REFERENCES. Where test-point references occur in the text or tables in this section, the test points appear without the identifying symbol; i.e., major test points are expressed as Arabic numerals with-

out the star and minor test points are expressed as capital letters without the circle.

6-4. TROUBLESHOOTING TABLE. Table XIV, the troubleshooting table, is to be used as a guide in troubleshooting the receiver. This table is based upon the signal-injection method of troubleshooting, in which a signal is supplied to the individual receiver stages, beginning at the output end and proceeding toward the antenna. Included in the table are the frequencies and amplitudes of the signals injected at each point and the normal receiver output voltage. The steps in the table are sequential and it is assumed that any trouble which might have been indicated in a preceding step has been cleared. Through the use of the troubleshooting table, a fault may be readily isolated to a specific circuit. To find the defective part within that circuit, the tube involved should be checked, and the tube voltage and resistances measured and compared to the values listed in tables XV and XVI.

TABLE XIV. TROUBLESHOOTING

<i>Symptom</i>	<i>Probable Cause</i>	<i>Remedy</i>
FRONT PANEL INDICATIONS		
1. Receiver operates on AM. but not on cw.	Defective b-f-o circuits	Refer to symptom 31.
2. Receiver operates but "RF GAIN" control has not effect.	Defective bias rectifier circuit	Refer to symptom 14.
3. Receiver inoperative on one of its six bands.	Defective r-f section	Refer to symptom 25.
4. Receiver inoperative on three lower bands; upper bands normal.	Defective gate circuit	Refer to symptom 21.
5. Receiver inoperative on three upper bands; lower bands normal.	Defective second conversion circuit	Refer to symptoms 23 and 24.
6. Receiver inoperative in "VFO" operation; operative in crystal-controlled mode.	Defective variable-frequency oscillator	Refer to symptom 25.
7. Receiver inoperative in crystal-controlled mode; operative in "VFO" mode.	Defective crystal-controlled oscillator circuit	Refer to symptom 26.
8. Receiver r-f tuning meter deflects during a-v-c operation but no audio output available at speaker or phones.	Defective audio amplifier circuits	Refer to symptoms 15 and 16.

TABLE XIV. TROUBLESHOOTING (Cont)

<i>Symptom</i>	<i>Probable Cause</i>	<i>Remedy</i>
9. Receiver output normal at speaker and phones but no output available at "IF OUTPUT" connector.	Defective cathode follower circuit	Refer to symptom 18.
10. Tuning meter operates normally for rf but does not indicate for af; receiver operates normally otherwise.	Defective output meter circuit	Refer to symptom 30.
POWER SUPPLY		
11. Receiver completely dead; pilot lamps out.	Defective power input circuit	Check for voltage at "AC" power outlet. If absent, check a-c source, power cable, and capacitors C158 and C168. Replace defective parts.
	Defective transformer primary circuit	Check fuse F1, switch S10 (part of "RF GAIN" control), and transformer T8. Replace defective parts.
12. Receiver inoperative but pilot lamps and tube filaments light; V18 does not glow.	Defective B-rectifier circuit	Check F2, V19, L51, L52, and R85. Replace defective parts.
13. Fuse F2 fails repeatedly; replacement fuses fail.	Short or ground in B+ line	Measure resistance to ground at test point 1. If less than 15k, proceed to step below. If 15k or higher, check high-voltage winding of T8 for shorts or grounds. Check receiver tubes for shorts.
	Defective "SEND/REC" circuit	Operate S9 to "SEND" position. If resistance at test point 1 increases to 15k, check C102, C163, C43, C40, C23, C21, C103, and C22 for shorts. Replace defective parts.
	Defective filter capacitors	Disconnect one end of C161A, C161B, and C161C and check for shorts or leakage. Replace if defective.
	Defective decoupling capacitor	Check decoupling filters in plate and screen circuits of remaining stages for shorts.
14. "RF GAIN" control ineffective; voltage at test point 2 zero or subnormal.	Defective bias rectifier circuit	Check V20, R86, R89, C158, C159, and C160. Replace defective parts.
AUDIO CIRCUITS		
15. 5.5-V, 400-cps signal coupled through 0.01 uf to test point F; audio output from receiver less than 20V.	Defective audio output circuit	Check V17, R98, R99, C151, C150, and T7. Replace any defective part.
16. 0.5-V, 400-cps signal applied through 0.01 uf to test point 3; "AUDIO GAIN" at max; receiver audio output less than 20V.	Defective first audio circuit	Check V16, R83, R81, R82, C148, C149, and shielded lead to grid of V16. Replace defective parts.

TABLE XIV. TROUBLESHOOTING (Cont)

Symptom	Probable Cause	Remedy
I-F CIRCUITS		
17. 0.6-V, 455-kc signal, AM. of 400 cps applied through 0.01 uf to test point G; "SELECTIVITY" switch set for 3 kc; "RF GAIN" and "AUDIO GAIN" controls at max; "LIMITER/OFF" switch set to "OFF"; "MOD/CW" switch set to "MOD"; "BAND CHANGE" control set to 1.35—3.45-mc band: audio output less than 20V.	Defective driver, second detector	Check jumper across "DIODE OUTPUT" terminals V11 and V14. Check V15 and V16 for shorts. Check C127, C128, C129A, C129B, C139, C141, C142, C143, R55, R56, R57, R58, R59, R61, R62, R63, R64, R65, and R113. Replace defective parts.
18. Receiver controls set as for symptom 17. Signal of 0.6V, 455 kc, AM. of 400 cps applied as under symptom 17: audio output of receiver normal; output at "IF OUTPUT" connector less than 200 millivolts.	Defective cathode follower circuit	Check V16, C145, C146, C147, R78, R79, L53, and socket J2. Replace defective parts.
19. 15,000 uv, 455 kc, AM. of 400 cps applied through 0.01 uf to test point H; receiver set as for symptom 17: audio output less than 20V.	Defective second i-f circuit	Check V10, T5, S5C, C121, C122, R51, and R52. Replace defective parts.
20. 300 uv, 455 kc, AM. of 400 cps applied through 0.01 uf to test point 4; receiver set as for symptom 17: audio output less than 20V.	Defective first i-f circuit	Check V9, T4, S5B, C115, C116, R43, R44, and R50. Replace defective parts.
21. 75 uv, 455 kc, AM. of 400 cps applied through 0.01 uf to test point I; receiver set as for symptom 17: audio output less than 20V.	Defective gate circuit	Check V7. Check V6 for shorts. Check R32, R39, R42, R53, C105, C165, S4, S5A, and T3. Replace defective parts.
22. 65 uv, 455 kc, AM. of 400 cps applied through 0.01 uf to test point 5; receiver set as for symptom 17; audio output less than 20V.	Defective first mixer circuit	Check V5, T1, C66, C68, C167, R26, R27, R28, and R33. Replace defective parts.
23. 100 uv, 3955 kc, AM. of 400 cps applied to test point J through 0.01 uf; receiver set as for symptom 17 except 7.40—14.8 mc band selected: audio output less than 20V.	Defective second mixer or 3.5-mc oscillator circuit	Check V6, V8, R36, R37, C106, S4, T2, and T3. Check 3.5-mc oscillator assembly. Replace defective parts.
24. 90 uv, 3955 kc, AM. of 400 cps applied to test point 5 through 0.01 uf; receiver set as for symptom 23: audio less than 20V.	Defective first mixer	Check V5, T1, and T2. Replace any defective parts.

TABLE XIV. TROUBLESHOOTING (Cont)

<i>Symptom</i>	<i>Probable Cause</i>	<i>Remedy</i>
R-F CIRCUITS		
25. Receiver set for "VFO" operation; "MOD/CW" switch to "MOD"; "RF GAIN" and "AUDIO GAIN" controls at max; "AVC/MAN" switch set to "MAN"; 2-uv signal at the receiver frequency, AM, of 400 cps applied to test point 6 through antenna test cable: audio output less than 20V.	Defective r-f circuits	Check V1, V2, and V4; check r-f coil subassemblies on band used. Check S2, antenna input connector, and main tuning condenser. Replace defective parts.
26. Receiver set for fixed-frequency reception. All other controls and connections as for symptom 25: audio output less than 20V.	Defective frequency control circuit	Check V3. Check crystal selected, switch S2, and frequency-control subassembly. Replace defective parts.
AUXILIARY CIRCUITS		
27. Receiver and signal generator set as for symptom 25 except receiver set for avc and signal input varied between 2 uv and 200,000 uv: receiver output varies more than 14 db (output voltage above 100V).	Defective a-v-c circuit	Check V14B, C138, C162, C140, C164, C169, S8, R61, R60, R111, R66, and R68. Replace defective parts.
28. Same as under symptom 27 except with receiver switched for c-w mode and V12 removed.	Defective a-v-c filter capacitor	Check C137. Replace.
29. Signal generator and receiver connections as for symptom 25 except input signal level 10 uv: tuning meter does not indicate +20 db.	Defective meter circuit	If meter needle does not deflect, check M1, S8, and S11. If meter indicates incorrectly, check R65 and R69. Readjust R69. Replace defective parts.
30. Signal generator and receiver connected as for symptom 25 except "AUDIO GAIN" control adjusted for 1.9-V receiver output: with "METER" switch in "AF" position, meter reads some value other than zero db.	Defective meter circuit	Check V15B, R10, R101, and S11. Readjust R101. Replace defective parts.
31. Signal generator and receiver connected as for symptom 25 except receiver set for c-w reception, 1-kc tone output; signal generator modulation off, signal input 0.75 uv: audio output from receiver less than 20V.	Defective b-f-o circuits	Check V13 and V12. Check adjustment of R74. Check C135, C136, S7, R75, R100, and T6. Replace defective parts.

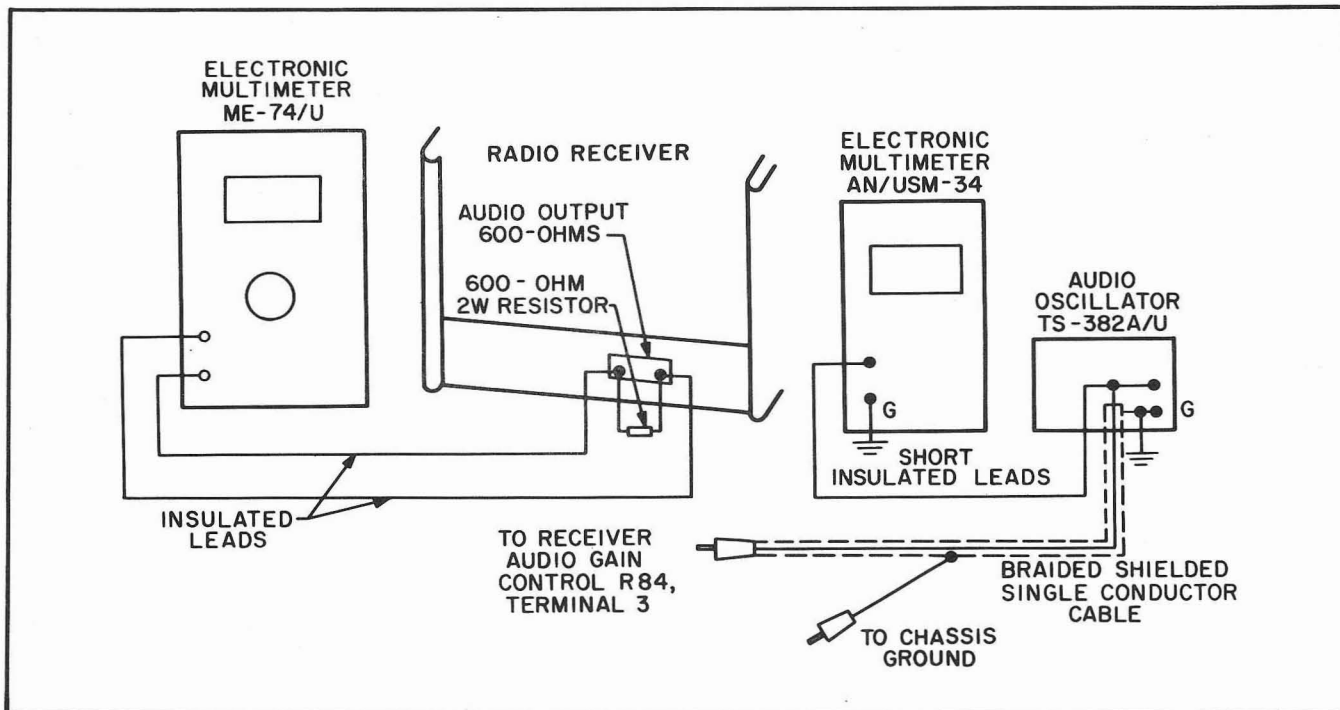

Figure 6-1. Receiver Audio Response Test Setup

TABLE XV. TUBE-SOCKET TERMINAL VOLTAGES

The voltages shown are all to chassis from the respective tube socket pins. Use a 20,000-ohm-per-volt voltmeter or a d-c vtvm to make the measurements. Keep the a-c line voltage at 117 volts and adjust the receiver for manual c-w operation, but with no signal input and the "AUDIO GAIN" control at minimum.

Tube	Socket Pin Numbers									Mode of Operation
	1	2	3	4	5	6	7	8	9	
V1	-1	—	6.3ac	—	200	95	—	—	—	"RF GAIN" max
V1	-41	—	6.3ac	—	260	245	—	—	—	"RF GAIN" min
V2	-1	—	6.3ac	—	210	95	—	—	—	"RF GAIN" max
V2	-41	—	6.3ac	—	260	245	—	—	—	"RF GAIN" min
V3	—	—	—	—	—	0	6.3ac	265	—	"RF GAIN" max, var freq osc operation
V3	—	—	—	—	—	150	6.3ac	265	—	"RF GAIN" max, crystal freq control
V3	—	—	—	—	—	0	6.3ac	290	—	"RF GAIN" min, var freq osc operation
V3	—	—	—	—	—	150	6.3ac	290	—	"RF GAIN" min, crystal freq control
V4	130	—	6.3ac	—	130	—	—	—	—	"RF GAIN" max or min
V5	—	1.2	6.3ac	—	140	110	—	—	—	"RF GAIN" max or min
V6	—	—	6.3ac	—	225	—	-1	—	—	"RF GAIN" max, freq below 7.4 mc

TABLE XV. TUBE-SOCKET TERMINAL VOLTAGES (Cont)

Tube	Socket Pin Numbers									Mode of Operation
	1	2	3	4	5	6	7	8	9	
V6	—	—	6.3ac	—	260	—	—55	—	—	"RF GAIN" min, freq below 7.4 mc
V6	—	—	6.3ac	—	225	80	—1	—	—	"RF GAIN" max, freq above 7.4 mc
V6	—	—	6.3ac	—	260	75	—55	—	—	"RF GAIN" min, freq above 7.4 mc
V7	—1	—	6.3ac	—	215	125	3.4	—	—	"RF GAIN" max, freq below 7.4 mc
V7	—54	—	6.3ac	—	265	245	0.4	—	—	"RF GAIN" min, freq below 7.4 mc
V7	—1	—	6.3ac	—	215	0	0	—	—	"RF GAIN" max, freq above 7.4 mc
V7	—54	—	6.3ac	—	265	0	0	—	—	"RF GAIN" min, freq above 7.4 mc
V8	0	—	6.3ac	—	0	—	—	—	—	Freq below 7.4 mc
V8	30	—	6.3ac	—	30	—	—	—	—	Freq above 7.4 mc
V9	—1	—	6.3ac	—	205	90	—	—	—	"RF GAIN" max
V9	—54	—	6.3ac	—	260	150	—	—	—	"RF GAIN" min
V10	—1	—	6.3ac	—	205	90	—	—	—	"RF GAIN" max
V10	—54	—	6.3ac	—	260	150	—	—	—	"RF GAIN" min
V11	—7.8	—	6.3ac	—	210	140	—	—	—	"RF GAIN" max
V11	—7.8	—	6.3ac	—	235	140	—	—	—	"RF GAIN" min
V12	—	—	6.3ac	—	210	40	—	—	—	"RF GAIN" max, b-f-o injection max
V12	—	—	6.3ac	—	240	45	—	—	—	"RF GAIN" min, b-f-o injection max
V13	25	—	6.3ac	—	25	—	—	—	—	"RF GAIN" max or min
V14	—	—	6.3ac	—	22	—	—	—	—	"RF GAIN" max or min
V15	—	—	6.3ac	—	—	—	—	—	—	"RF GAIN" max or min
V16	50	—	1.5	—	—	210	—	6.4	6.3ac	"RF GAIN" max
V16	57	—	1.6	—	—	240	—	7.4	6.3ac	"RF GAIN" min
V17	—	—	260	228	—	—	6.3ac	12	—	"RF GAIN" max
V17	—	—	280	265	—	—	6.3ac	13	—	"RF GAIN" min
V18	150	—	—	—	150	—	—	—	—	"RF GAIN" max or min
V19	—	300	—	—	—	—	—	300	—	"RF GAIN" max, 5.0 ac pin 2 to pin 8
V19	—	320	—	—	—	—	—	320	—	"RF GAIN" min, 5.0 ac pin 2 to pin 8
V20	—	—96	6.3ac	—	—	—	—96	—	—	"RF GAIN" max
V20	—	—97	6.3ac	—	—	—	—97	—	—	"RF GAIN" min

TABLE XVI. TUBE-SOCKET TERMINAL RESISTANCES

The resistance values shown are all to chassis from the respective tube socket pins with the tube removed from the socket under measurement. Use a volt-ohmmeter to make the measurements. Keep the "AUDIO GAIN" control at maximum, the "RF GAIN" control at minimum, the "LIMITER/OFF" switch at "OFF", and set the receiver for c-w, a-v-c operation.

Tube	Socket Pin Numbers									Mode of Operation
	1	2	3	4	5	6	7	8	9	
V1	1800k	0	—	0	16.7k	50k	0	—	—	
V2	1800k	0	—	0	16.7k	50k	0	—	—	
V3	0	—	0	47k	0	17.5k	—	15.6k	—	Crystal freq control positions 1-6
V4	inf	inf	—	0	inf	47k	0	—	—	Crystal freq control positions 1-6
V4	19k	inf	—	0	inf	47k	0	—	—	Var freq osc operation
V5	47k	150	—	0	19k	22k	26k	—	—	Freq band 1.35 — 3.45 mc
V6	22k	0	—	0	17.4k	inf	1100k	—	—	Freq bands below 7.4 mc
V6	22k	0	—	0	17.4k	37.4k	1100k	—	—	Freq bands above 7.4 mc
V7	980k	0	—	0	17.4k	inf	390	—	—	Freq bands above 7.4 mc
V7	980k	0	—	0	17.4k	48k	390	—	—	Freq bands below 7.4 mc
V8	—	—	—	0	inf	22k	0	—	—	Freq bands below 7.4 mc
V8	—	—	—	0	117k	22k	0	—	—	Freq bands above 7.4 mc
V9	1100k	0	—	0	17.5k	9.5k	0	—	—	
V10	1100k	0	—	0	17.5k	9.5k	0	—	—	
V11	93k	0	—	0	17.5k	19k	0	—	—	
V12	1.5	0	—	0	17.5k	115k	*	—	—	* 0 to 1k ("BFO INJ" control)
V13	—	—	—	0	162k	100k	0	—	—	
V14	0	816k	—	0	15.6k	0	196k	—	—	
V15	69k	inf	—	0	inf	0	196k	—	—	
V16	125k	500k	1k	0	0	17.4k	470k	680	—	
V17	0	0	15.6k	15.2k	470k	inf	—	360	—	
V18	118k	—	—	—	20k	—	0	—	—	
V19	—	15.8k	0	42	—	40	—	15.8k	—	
V20	49k	65k	—	0	49k	0	65k	—	—	

6-5. TUBE VOLTAGES AND RESISTANCES. Table XV, covering tube-socket terminal voltages, is to be used in conjunction with table XIV and tables XVI and XVII to locate a defective part within the receiver. The table lists the normal voltages measured between the tube-socket terminals and ground, using a 20,000-ohm-per-volt voltmeter or a vtvm. Any appreciable departure in readings beyond a normal variation of approximately

15 percent will generally indicate the component at fault.

Note

Use a tube adapter to gain access to the tube socket terminals of tubes V1, V2, V3, V4, and V5.

6-6. Table XVI lists the normal resistances measured between the tube-socket terminals and ground. The

measurements at each socket were made with the tube removed. Table XVII lists the d-c resistance of each choke, coil, and transformer used in the receiver. In instances where the resistance is very low, the table indicates that a continuity "click" check suffices. The data are useful when checking the parts listed for open or shorted turns. In each instance, a resistance tolerance of plus or minus 15 percent applies, since the data provided represent practical averages determined from lots of each item.

6-7. REMOVAL AND REPLACEMENT.

6-8. GENERAL. For removal and replacement of specific parts or subassemblies, the procedures outlined for each must be followed. For removal and replacement procedures applicable to the r-f tuner subassemblies, or to the i-f transformer and 3.5-mc crystal heterodyne subassemblies, refer to paragraphs 5-17 and 5-18, respectively.

6-9. FREQUENCY CONTROL UNIT. If the frequency control unit has been found to be defective, remove the unit for repair or replacement as follows:

a. To remove the unit, unsolder the lead of capacitor C60 from the "FREQ CONTROL" selector switch. Unsolder the black, black/white, blue/red, and red/white leads of the frequency control unit from the terminal strip underneath the chassis and unsolder the red lead of the unit from filter capacitor C161. Set the "FREQ CONTROL" selector switch to its "3" position, and loosen the four setscrews in the rigid shaft coupling and the two setscrews in the disc on the selector switch shaft. Slide the switch shaft forward through the coupling and disc. Loosen the setscrews of the "Δ FREQ" control knob and remove the knob. Remove the nut and lock-washer at the top of the bracket post adjacent to the power transformer and remove the bracket over the filter chokes. Remove the four No. 8-32 mounting screws from the bottom of the chassis and lift out the crystal control unit.

TABLE XVII. D-C RESISTANCE OF COILS AND WINDINGS

Reference Symbol	Winding or Terminals	Resistance (Ohms)	Reference Symbol	Winding or Terminals	Resistance (Ohms)
T7	1-3	41.6	L31	Primary	Click
	2-4	41.3		Secondary	1.17
	5-6	685.0	L32	Primary	5.35
	7-8	426.0		Secondary	0.68
T8	1-9	30.8	L33	Primary	Click
	10-12	62.3		Secondary	1.65
	13-14	0.47	L34		1.55
	15-16	0.47		L35	
	17-18	0.42	L36		Primary
	19-20	0.42		Secondary	2.77
L1	Primary	1.43	L37		9.42
	Secondary	9.0			3.62
L2	Primary	Click	L38, L39, L41, L42		
	Secondary	1.4		L40, L43	Per pie
L3 thru L6 L10 thru L13 L17 thru L20 L27 thru L30	Primary Secondary	Click Click	L44		
			L45		2.50
			L46		1.31
			L47		46.0
			L48		2.0
L7, L14		8.5	L49, L50		2.7
L24		25		L51	
L8, L15	Primary	Click	L52		354.0
	Secondary	9.2		L53	Start to finish
L9, L16	Primary	Click	Start to tap		6.0
	Secondary	1.25			
L21		21.5			
L22		88.0			
L23		177.0			
L25	Primary	1.15			
	Secondary	6.8			

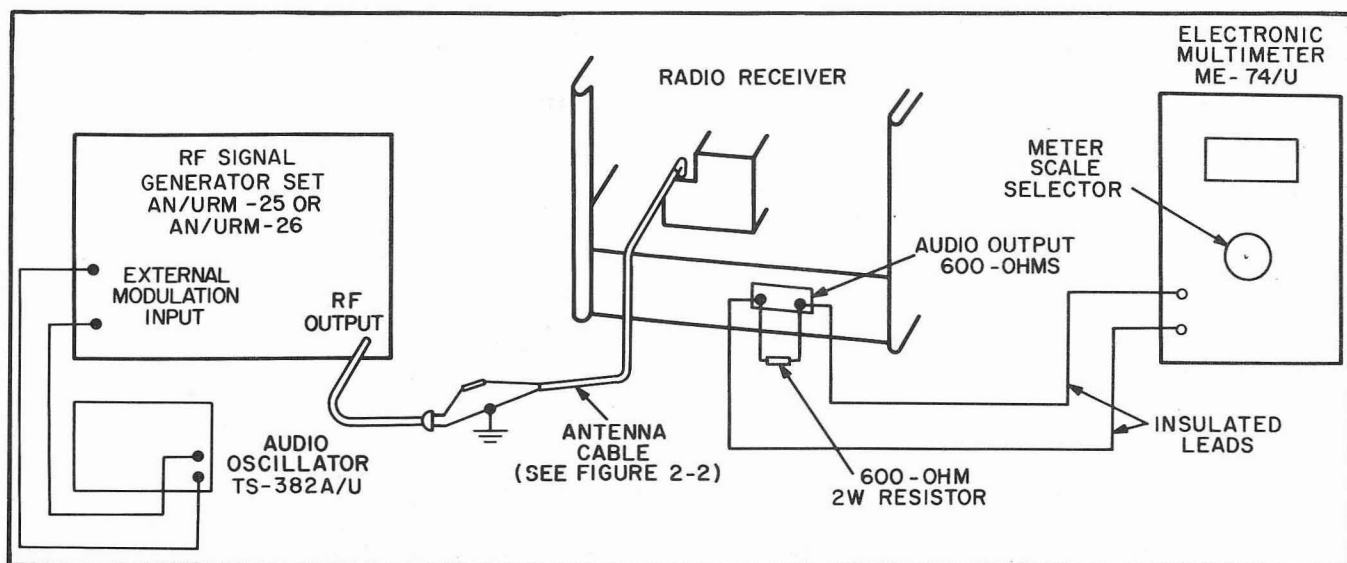

Figure 6-2. Receiver Overall Response Test Setup

CAUTION

In removing the unit, and in subsequent handling, be careful to avoid any strain on the "△FREQ" control shaft; a strain on the control shaft may damage the delta frequency variable capacitor.

b. To replace the unit, follow the reverse procedure. When inserting the "FREQ CONTROL" selector switch shaft, carefully slide the shaft through the disc into the rigid coupling and tighten the four setscrews in the rigid coupling with the knob indicator at the "3" position. Then set the "FREQ CONTROL" selector switch to the "1" position and lightly fasten the setscrews of the disc, while holding the disc in a counterclockwise direction so that the end of the slot in the disc is against the drive pin. When the disc is properly adjusted, the connecting bar between the two discs should not be under tension, and should exhibit a slight amount of play when tried with the thumb and forefinger. When the assembly is so adjusted, tighten the setscrews.

6-10. MIXER TRANSFORMER. To remove and replace mixer transformer T1, proceed as follows:

a. To remove the mixer transformer, first remove the crystal control unit as described in paragraph 6-9. Then remove the chassis side shield by removing the ten No. 10-32 and two No. 6-32 screws from the side, and the four No. 10-32 screws from the front panel. Remove the two No. 6-32 cap nuts to remove the mixer cover and the six No. 6-32 screws to remove the mixer shield. Unsolder all ten leads at the top terminal board and all five leads at the bottom terminal board. Remove the four No. 6-32 screws and remove the mixer transformer.

b. To replace the unit, follow the reverse procedure.

6-11. R-F STRIP. If the receiver fails to operate normally on any of its six frequency bands and the trouble has been localized to the r-f strip, the subassembly must

be removed to provide access to its parts. The removal and replacement should be performed as follows:

a. To remove the unit, remove the ten No. 6-32 screws at the top shield of the tuning capacitor assembly and remove the shield. Remove the shield cover of the mixer transformer by removing the two No. 6-32 cap nuts from the unit. Unsolder the blue, white/black, red/white, red/green, yellow/black, and blue/red leads that come from the r-f strip at the top of mixer transformer T1. Unsolder the leads from the tuning capacitor rotors, stators, and ground straps at each section. Unsolder the lead from the r-f strip at switch S3. Turn the "BAND CHANGE" control one-half turn from any band position in order to have the switch contacts disengaged. Leave the switch in this position until the r-f strip is replaced, to prevent damage to the switch contacts. Remove the four No. 6-32 screws from the top of the r-f strip and the four No. 6-32 screws from the side. Carefully lift out the r-f strip.

b. To replace the r-f strip, follow the reverse procedure.

6-12. MAIN TUNING CAPACITOR. If it is necessary to replace the main tuning capacitor, proceed as follows:

a. To remove the capacitor, first remove the top cover and unsolder the leads as described in paragraph 6-11. Mesh the capacitor fully by means of the "TUNING" control. Carefully remove the spring and drive link at the front of the capacitor. Loop a piece of small wire around the spacing washer between the capacitor and the gearplate, and remove the single screw that secures the capacitor frame front plate to the gearplate. The capacitor front plate is held in position by two dowel pins and will not move when the front screw is removed. Hold the capacitor by its frame with one hand and remove the rear supporting screw and spacer. Move the capacitor to the rear to disengage the dowel pins, and lift it from the receiver.

b. Follow the above procedure in reverse to replace the capacitor.

6-13. FRONT PANEL.

a. To remove the front panel, first remove the "BEAT OSC.", "RF GAIN", "TUNING", "BAND CHANGE", and "AUDIO GAIN" control knobs from the front panel. Then remove the nuts on all toggle switches and on the "PHONES" jack on the front panel. Remove the ten No. 10-32 front panel mounting screws and washers. Disconnect all flexible couplings to the front panel shafts. Remove the meter strip from its meter terminal mounting.

b. To replace the front panel, follow the above instructions in reverse.

6-14. RECEIVER ALIGNMENT AND ADJUSTMENT.

6-15. GENERAL. Since the radio receiver utilizes the principle of double conversion, the alignment procedure is necessarily complex and requires precision equipment and a thorough knowledge of the circuits involved. For this reason, alignment should not be attempted unless all other possible means of remedying a particular trouble have been eliminated. When it has been determined that alignment is necessary, caution should be exercised in making the adjustments, since the adjustments required should not entail more than a slight angular motion of the adjusting screw.

6-16. ALIGNMENT PROCEDURE. The alignment procedure for the receiver follows a definite sequence: the alignment of the 455-kc i-f section first; then the alignment of the 3955-kc i-f section; and finally the alignment of the r-f amplifiers and first conversion oscillator on each of the six bands. Table XVIII outlines the step-by-step sequence to be followed in the alignment procedure. When receiver repair confines the necessary alignment to a specific receiver section, only the appropriate alignment steps need be performed. The receiver

front-panel controls are referred to in the table by their panel designations (see figure 1-2) and the rear-apron controls by their rear-apron designations (see figure 1-3). For the location of all other alignment adjustment means, see figure 5-5. The receiver i-f alignment procedures are outlined for both output meter and oscilloscope indications. Where suitable equipment is available, the latter method is preferable.

Note

Do not attempt to align the receiver unless tube-socket voltages (refer to table XV) and tube-socket resistances (refer to table XVI) are normal.

6-17. RECEIVER PERFORMANCE TESTS.

6-18. After a receiver has undergone repair or alignment, it should be subjected to the receiver performance tests outlined in table XIX before it is released to an operational activity. The performance tests outlined in table XIX are designed to supplement those of table IX and are more detailed, since test equipment of greater precision is normally available to field maintenance activities. If the receiver fails to meet any of the minimum performance standards listed in table XIX, corrective maintenance should be performed before the receiver is released for use.

6-19. PREVENTIVE MAINTENANCE.

6-20. LUBRICATION. All parts requiring lubrication have been adequately treated at the factory and no lubrication within the scope of field maintenance activities is required. All the receiver subassemblies provided as replacements may be used without the need for lubrication, since they have been conditioned at the factory for immediate use.

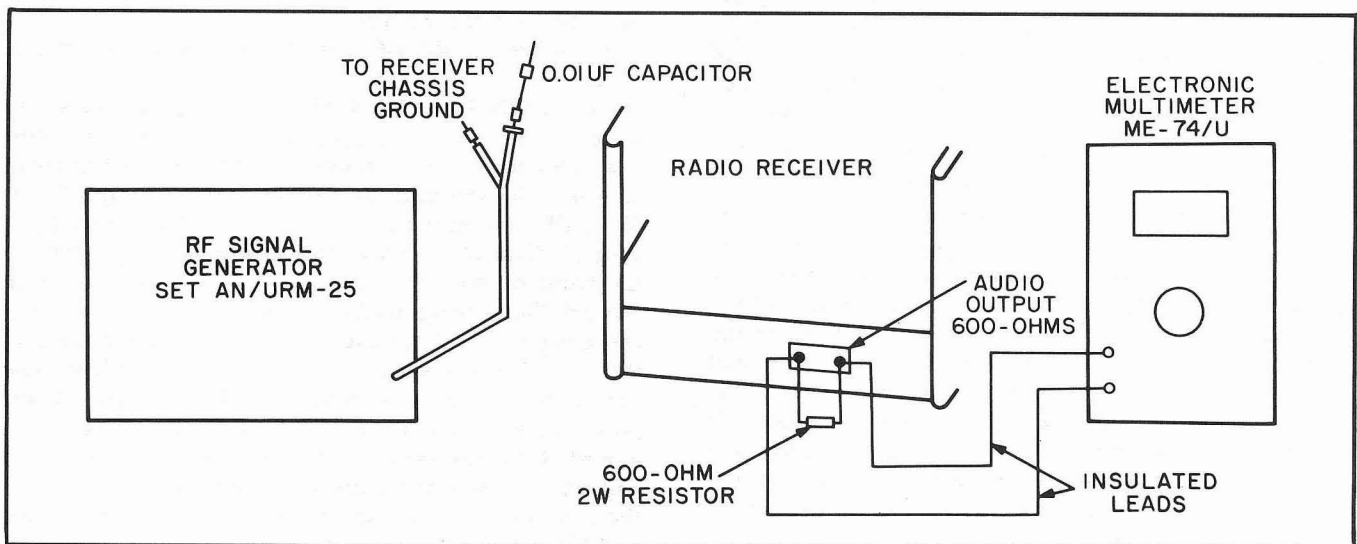

Figure 6-3. Test Setup for Alignment of Receiver I-F Stages

TABLE XVIII. RECEIVER ALIGNMENT AND ADJUSTMENT PROCEDURES

Step	Test Equipment Adjustment	Receiver Control Positions	Alignment or Adjustment
1	<p>Test setup as per fig. 6-3.</p> <p>Adjust signal gen to provide 455-kc, 30-percent 400-cps A-M signal. Connect output of signal gen thru 0.01 uf to test point 5 (pin 7 of mixer V5) using tube adapter to gain access to test point. Adjust signal gen output level to provide usable deflection on output meter.</p> <p>Reduce signal gen output level as rec is aligned to prevent rec overload or excessive output.</p>	<p>"SEND/REC" switch to "REC".</p> <p>"MOD/CW" switch to "MOD".</p> <p>"AVC/MAN" switch to "MAN".</p> <p>"SELECTIVITY" switch to 3-kc position.</p> <p>"AUDIO GAIN" control at max; use approx 20 volts output meter indication.</p> <p>"BAND CHANGE" control for 1.35-3.45-mc band.</p> <p>"TUNING" control for 2.5 mc.</p> <p>"XTAL PHASING" control to arrow.</p> <p>"RF GAIN" control at max; then, as rec alignment is made, reduce to prevent excessive output.</p> <p>"LIMITER/OFF" switch to "OFF".</p>	Adjust, in turn, L42, L41, L39, L38, L36, L32 for max output.
2	Carefully readjust signal gen to resonant freq of rec crystal filter by adjusting for max rec output. Maintain this signal gen setting for steps 3, 4, and 5.	"SELECTIVITY" switch to 0.2-kc position; others as in step 1.	None
3	None	"SELECTIVITY" switch back to 3-kc position; others as in step 1.	Readjust, in turn, L42, L41, L39, L38, L36, L32 for max output.
4	None	"SELECTIVITY" switch to 1.3-kc position; others as in step 1.	Adjust L37 for max output.
5	Same as step 2 but with signal gen AM. switched off.	Same as step 4 but with "MOD/CW" switch in "CW". Set "BEAT OSC." control to "O" dial position. Allow 15-minute warmup period.	Adjust L44 for zero output.
6	Same as step 1, but signal gen input of 3955 kc, 30-percent 400-cps AM.	"SELECTIVITY" switch to 3-kc position; "BAND CHANGE" control for 7.4-14.8-mc band; others as in step 1.	Adjust, in turn, L31, L33, L34 for max output.
7	<p>Test setup as per fig. 5-1.</p> <p>Adjust signal gen to provide 0.56-mc, 30-percent, 400-cps A-M signal. Connect signal gen output to antenna input connector J1 (see figure 5-5) using antenna input cable (see figure 2-2). Adjust signal gen output level to provide usable deflection on output meter.</p> <p>Reduce signal level as rec is aligned, to prevent rec overload.</p>	<p>"SELECTIVITY" switch to 3-kc position.</p> <p>"SEND/REC" switch to "REC".</p> <p>"FREQ CONTROL" selector switch to "VFO".</p> <p>"MOD/CW" switch to "MOD".</p> <p>"AUDIO GAIN" control at max; use approx 20 volts output meter indication.</p> <p>"BAND CHANGE" control for 0.54-1.35-mc band.</p> <p>"TUNING" control for 0.56-mc main dial indication.</p> <p>"LIMITER/OFF" switch to "OFF".</p> <p>"RF GAIN" control at max.</p> <p>"AVC/MAN" switch to "AVC".</p>	Adjust, in turn, L25, L1, L8, L15 for max output.

TABLE XVIII. RECEIVER ALIGNMENT AND ADJUSTMENT PROCEDURES (Cont)

Step	Test Equipment Adjustment	Receiver Control Positions	Alignment or Adjustment
8	Same as for step 7 but signal gen input of 1.3 mc, 30-percent 400-cps AM.	Same as step 7 but set "TUNING" control for 1.3-mc main dial indication.	Adjust, in turn, C76, C2, C26, C46 for max output.
9	Repeat step 7 and step 8 in sequence.	Repeat step 7 and step 8 in sequence.	Repeat step 7 and step 8 in sequence until no further increase in output results.
10	Same as step 9 but set signal gen level to approx 3 uv.	Same as step 9 but set "AVC/MAN" switch to "MAN". "RF GAIN" control set to maintain approx 20 volts output meter indication as rec is aligned.	Same as step 9; repeat as needed.
11	Same as step 7 but signal gen input of 1.4 mc, 30-percent 400-cps AM.	Same as step 7 but "BAND CHANGE" control for 1.35–3.45-mc band; "TUNING" control for 1.4-mc main dial indication.	Adjust, in turn, L26, L2, L9, L16 for max output.
12	Same as step 8 but signal gen input of 3.4 mc, 30-percent 400-cps AM.	Same as step 7 but set "TUNING" control for 3.4-mc main dial indication.	Adjust, in turn, C81, C4, C28, C48 for max output.
13	Repeat step 11 and step 12 in sequence.	Repeat step 11 and step 12 in sequence.	Repeat step 11 and step 12 in sequence until no further increase in output results.
14	Same as step 13 but set signal gen level to approx 3 uv.	Same as step 13 but set rec controls as in step 10.	Same as step 13; repeat as needed.
15	Same as step 7 but signal gen input of 3.75 mc, 30-percent 400-cps AM.	Same as step 7 but "BAND CHANGE" control for 3.45–7.4-mc band; "TUNING" control for 3.75 mc.	Adjust, in turn, L27, L3, L10, L17 for max output.
16	Same as step 8 but signal gen input of 7.15 mc, 30-percent 400-cps AM.	Same as step 7 but set "TUNING" control for 7.15-mc main dial indication.	Adjust, in turn, C84, C7, C31, C51 for max output.
17	Repeat step 15 and step 16 in sequence.	Repeat step 15 and step 16 in sequence.	Repeat step 15 and step 16 in sequence until no further increase in output results.
18	Same as step 17 but set signal gen level to approx 3 uv.	Same as step 17 but set rec controls as in step 10.	Same as step 17; repeat as needed.
19	Same as step 7 but signal gen input of 7.5 mc, 30-percent 400-cps AM.	Same as step 7 but "BAND CHANGE" control for 7.4–14.8-mc band; "TUNING" control for 7.5 mc.	Adjust, in turn, L28, L4, L11, L18 for max output.
20	Same as step 8 but signal gen input of 14.5 mc, 30-percent 400-cps AM.	Same as step 7 but set "TUNING" control for 14.5-mc main dial indication.	Adjust, in turn, C86, C10, C34, C54 for max output.
21	Repeat step 19 and step 20 in sequence.	Repeat step 19 and step 20 in sequence.	Repeat step 19 and step 20 in sequence until no further increase in output results.

TABLE XVIII. RECEIVER ALIGNMENT AND ADJUSTMENT PROCEDURES (Cont)

Step	Test Equipment Adjustment	Receiver Control Positions	Alignment or Adjustment
22	Same as step 21 but set signal gen level to approx 3 uv.	Same as step 21 but set rec controls as in step 10.	Same as step 21; repeat as needed.
23	Same as step 7 but signal gen input of 15.0 mc, 30-percent 400-cps AM.	Same as step 19 but "BAND CHANGE" control for 14.8–29.7-mc band; "TUNING" control for 15.0 mc.	Adjust, in turn, L29, L5, L12, L19 for max output.
24	Same as step 8 but signal gen input of 29.0 mc, 30-percent 400-cps AM.	Same as step 19 but set "TUNING" control for 29.0-mc main dial indication.	Adjust, in turn, C90, C13, C36, C56 for max output.
25	Repeat step 23 and step 24 in sequence.	Repeat step 23 and step 24 in sequence.	Repeat step 23 and step 24 in sequence until no further increase in output results.
26	Same as step 25 but set signal gen level to approx 3 uv.	Same as step 25 but set rec controls as in step 10.	Same as step 25; repeat as needed.
27	Same as step 7 but signal gen input of 30.0 mc, 30-percent 400-cps AM.	Same as step 19 but "BAND CHANGE" control for 29.7–54.0-mc band; "TUNING" control for 30.0 mc.	Adjust, in turn, L30, L6, L13, L20 for max output.
28	Same as step 8 but signal gen input of 52.0 mc, 30-percent 400-cps AM.	Same as step 7 but set "TUNING" control for 52.0-mc main dial indication.	Adjust, in turn, C94, C16, C38, C58 for max output.
29	Repeat step 27 and step 28 in sequence.	Repeat step 27 and step 28 in sequence.	Repeat step 27 and step 28 in sequence until no further increase in output results.
30	Same as step 29 but set signal gen level to approx 3 uv.	Same as step 28 but set rec controls as in step 10.	Same as step 29; repeat as needed.
Alternate for steps 1 thru 5	Test setup as per fig. 6–4. Adjust signal gen to provide 455 \pm 20-kc F-M signal. Connect signal gen output thru 0.01 uf to test point 5 (pin 7 of V5) using tube adapter to gain access to test point. Connect oscilloscope vertical input terminals between jumpered "DIODE OUTPUT" terminals and ground. Adjust signal gen level and sweep to provide good oscilloscope image.	Same as steps 1 thru 5.	Same as steps 1 thru 5 but make adjustments for both max amplitude and oscilloscope image coincidence, using crystal filter as a reference to establish correct nominal 455-kc freq or sweep signal gen as in step 2.
Alternate for step 6	Same as alternate for steps 1 thru 5 except adjust signal gen to provide 3955 \pm 20-kc F-M signal.	Same as step 6.	Same as step 6 but make adjustments for both max amplitude and oscilloscope image coincidence.

TABLE XIX. RECEIVER PERFORMANCE TESTS

Test	Control Settings	Procedure and Minimum Performance Standard Requirements	Possible Source of Trouble
Audio Fidelity	<p>Set receiver "RF GAIN" control to min and "AUDIO GAIN" control to max.</p> <p>Set audio oscillator frequency to 400 cps and adjust input level to receiver to provide 10-mw receiver output (10 db on Electronic Multimeter ME-74/U).</p>	<p>Connect equipment as shown in figure 6-1.</p> <p>Note carefully input level to receiver for 10-mw receiver output.</p> <p>Maintaining same input level noted above, adjust audio oscillator frequency in small steps over range of 50 to 10,000 cps. Note and record receiver output for each frequency. On semi-log graph paper, plot a graph of output attenuation in db against audio frequency. (Subtract db reading obtained on Electronic Multimeter ME-74/U at each frequency from 10 db to find attenuation in db.) Audio fidelity of receiver should approximate that shown in figure 1-5.</p>	A-f section: T7, C148, C149, C150
Overall Fidelity	<p>Set r-f signal generator to any frequency within range of receiver. Set audio oscillator for 400 cps and adjust level to provide 30-percent A-M signal.</p> <p>Set receiver "RF GAIN" control to max; "AVC/MAN" switch to "MAN"; "SELECTIVITY" switch to 3-kc position; "MOD/CW" switch to "MOD".</p> <p>Set "SELECTIVITY" switch to 13.0-kc position.</p>	<p>Connect equipment as shown in figure 6-2.</p> <p>Tune receiver to r-f signal generator frequency. Advance "AUDIO GAIN" control to max and adjust "RF GAIN" control for 10-mw receiver output (10 db on electronic multimeter).</p> <p>Adjust audio oscillator frequency in small steps over frequency range of 50 to 10,000 cps, being careful to maintain an output level providing 30-percent AM. Note and record receiver output for each frequency. On semi-log graph paper, plot a graph of output attenuation in db against audio frequency. (Output attenuation in db equals 10 db minus db reading obtained on electronic multimeter.) Overall fidelity of receiver should approximate that shown in figure 1-5.</p>	I-f section: T1, T3, T4, T5 for signal below 7.4 mc; T1, T2, T3, T4, T5 for signal above 7.4 mc
Frequency Accuracy	Set receiver controls for c-w operation.	<p>Turn receiver on and allow 15-minute warmup period.</p> <p>Connect two-foot length of insulated wire to receiver antenna input connector and dress free end around shield of tube V8 (3.5-mc crystal oscillator tube).</p> <p>Tune receiver to successive harmonics of 3.5 mc, beginning with frequency of 10.5 mc. Note carefully main tuning dial indication for each signal frequency tuned in. Main dial accuracy should be within 0.25 percent of signal frequency over range of receiver.</p>	R-f section: main tuning capacitor sections C1G and C1H if calibration is off on all bands; oscillator r-f tuner sub-assembly if only one band is inaccurate
A-V-C Action	Set signal generator for A-M, 400-cps, 30-percent-modulated, 2-uv signal at any frequency within range of receiver.	Connect equipment as shown in figure 5-1.	

TABLE XIX. RECEIVER PERFORMANCE TESTS (Cont)

Test	Control Settings	Procedure and Minimum Performance Standard Requirements	Possible Source of Trouble
	Set receiver "RF GAIN" control to max; "AVC/MAN" switch to "MAN"; "SELECTIVITY" switch to 3-kc position; "MOD/CW" switch to "MOD".	Tune receiver to signal generator frequency. Adjust "AUDIO GAIN" control for receiver output of 10 mw (10 db on Electronic Multimeter ME-74/U). Vary signal generator output from 2 uv to 200,000 uv, noting receiver output indication. Receiver output should remain constant within 14 db. (Electronic multimeter reading should be within range of 10 to 24 db.)	A-v-c section: V14B
Frequency Stability	Set signal generator and receiver controls same as for a-v-c action test.	(Equipment connected as shown in figure 5-1.) After 15-minute warmup period, tune receiver accurately to signal generator frequency. Note and record main and vernier dial readings. At half-hour intervals, retune receiver, record dial readings, and compare with original dial readings. Frequency drift should be between 0.001 and 0.01 percent of signal frequency.	R-f section: C79, C80

6-21. INSPECTION. The useful life of the radio receiver may be prolonged by regular inspection and necessary preventive maintenance. A thorough inspection of the receiver often discloses minor electrical or mechanical defects which, if not corrected, may result in receiver failure during operational use. The receiver should, therefore, be inspected regularly, as follows:

a. Inspect the receiver for dirt, dust, and corrosion; tropicalization of r-f coils, chokes, and soldered joints; evidence of oil leakage; loose subassemblies, trimmers, and adjustable cores; poor soldering; and partly broken leads.

b. Inspect the U-shaped loop spring used to retain the main tuning capacitor drive link to see that it is properly seated and not stretched.

c. Inspect the three double U spider loop springs used in the gear train to prevent backlash to see that each is properly seated and not misshaped.

d. Remove all the r-f tuner subassemblies except those for one band and inspect the knife action of the contact pins on the r-f tuner subassemblies. Check to see that the V contact spring blades for the r-f tuner subassemblies on the r-f strip are spread uniformly, not broken, and provide positive electrical contact.

e. Inspect the forked flat spring at the rear of the turret assembly to see that it bears against the turret rotor and prevents end play.

f. Inspect the spring at the front of the turret rotor assembly to see that it is not misshaped.

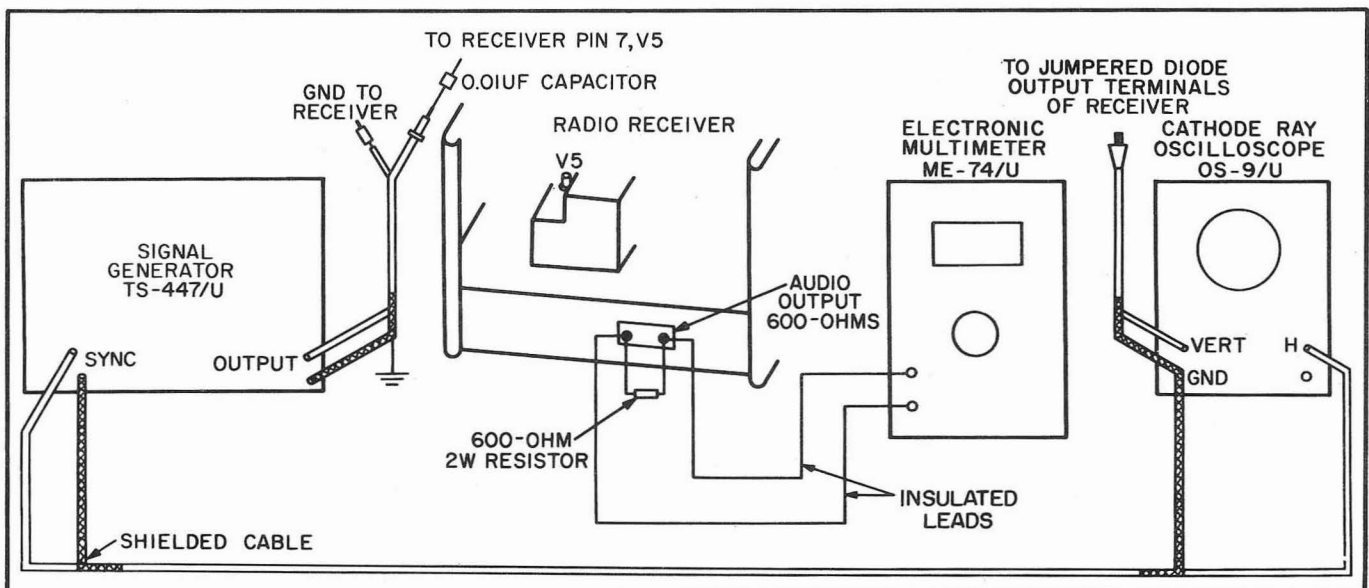

Figure 6-4. Alternate Test Setup for Alignment of Receiver I-F Stages

g. Inspect the three flat springs used to ground the turret rotor shaft to see that they provide positive electrical contact.

h. Inspect the flat spring used for grounding each i-f transformer shield, the two flat springs used to retain each r-f coil, and the two flat springs used to retain the r-f tuner subassemblies to see that positive spring action is provided.

i. Inspect the two helical springs on the "BAND CHANGE" control to see that they provide positive detent action; also inspect similar type springs used to provide indicator slide action and to provide holding action of the conversion switch located at the rear of the turret rotor assembly.

6-22. OVERHAUL SCHEDULE.

6-23. The overhaul schedule of the receiver is dependent upon the operating conditions to which it has been subjected in normal use. When a receiver is turned in to

maintenance activities for repair, the need for depot overhaul can be determined by inspection. Otherwise, a receiver should be scheduled for overhaul according to table XX.

TABLE XX. RECEIVER OVERHAUL SCHEDULE

<i>Class of Service</i>	<i>Elapsed Time</i>
Fixed station	12 months
Field station	6 months
Mobile field	3 months
Airborne	3 months
Any, at high relative humidity and/or temperature	1 month

SECTION VII

DIAGRAMS

7-1. GENERAL.

7-2. This section comprises a schematic diagram of the radio receiver and tube-socket terminal voltage and resistance diagrams which are intended for use in receiver trouble analysis. The diagrams supplement the information included under paragraphs 5-6 and 6-1.

7-3. INDEX OF DIAGRAMS.

7-4. The following is an index of the diagrams included in Section VII:

Figure No.	Title
7-1	Radio Receiver, Schematic Diagram
7-2	Tube-socket Terminal Voltage Diagram
7-3	Tube-socket Terminal Resistance Diagram

7-5. TUBE-SOCKET TERMINAL VOLTAGE DIAGRAM.

7-6. To obtain access to the tube-socket terminals of tubes V1, V2, V3, V4, and V5, use a tube adapter. All

other tube-socket terminals are accessible from the bottom of the radio receiver. The voltage values listed in figure 7-2 are all with reference to chassis ground except where noted otherwise. Unless indicated otherwise, all voltages are dc. The readings were obtained with a vtvm. The 500-volt scale was used for all voltages above 10 volts and the 10-volt scale for voltages below 10 volts. Line voltage was 117 volts, with no signal applied to the receiver. The receiver "AUDIO GAIN" control (16, figure 1-2) was set to minimum; the "RF GAIN" control (12) to maximum; and the "MOD/CW" switch (13) to "CW".

7-7. TUBE-SOCKET TERMINAL RESISTANCE DIAGRAM.

7-8. Resistance values listed in figure 7-3 are all with reference to chassis ground. The readings were obtained with the tube removed from the socket under measurement; the "RF GAIN" control (12, figure 1-2) was set to minimum; the "AUDIO GAIN" control (16) to maximum; the "LIMITER/OFF" switch (19) to "OFF"; the "MOD/CW" switch (13) to "CW"; and the "AVC/MAN" switch (11) to "AVC".

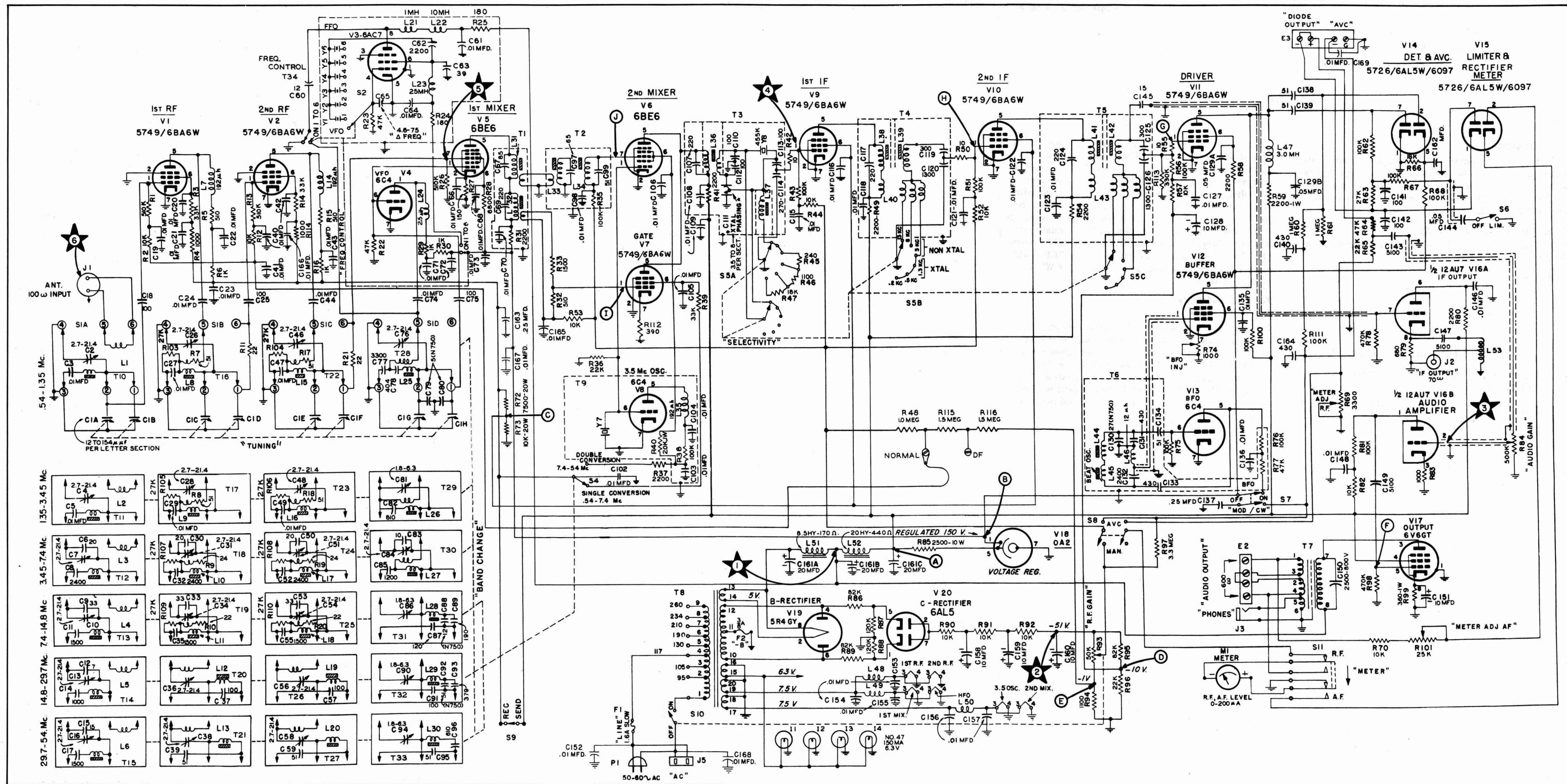

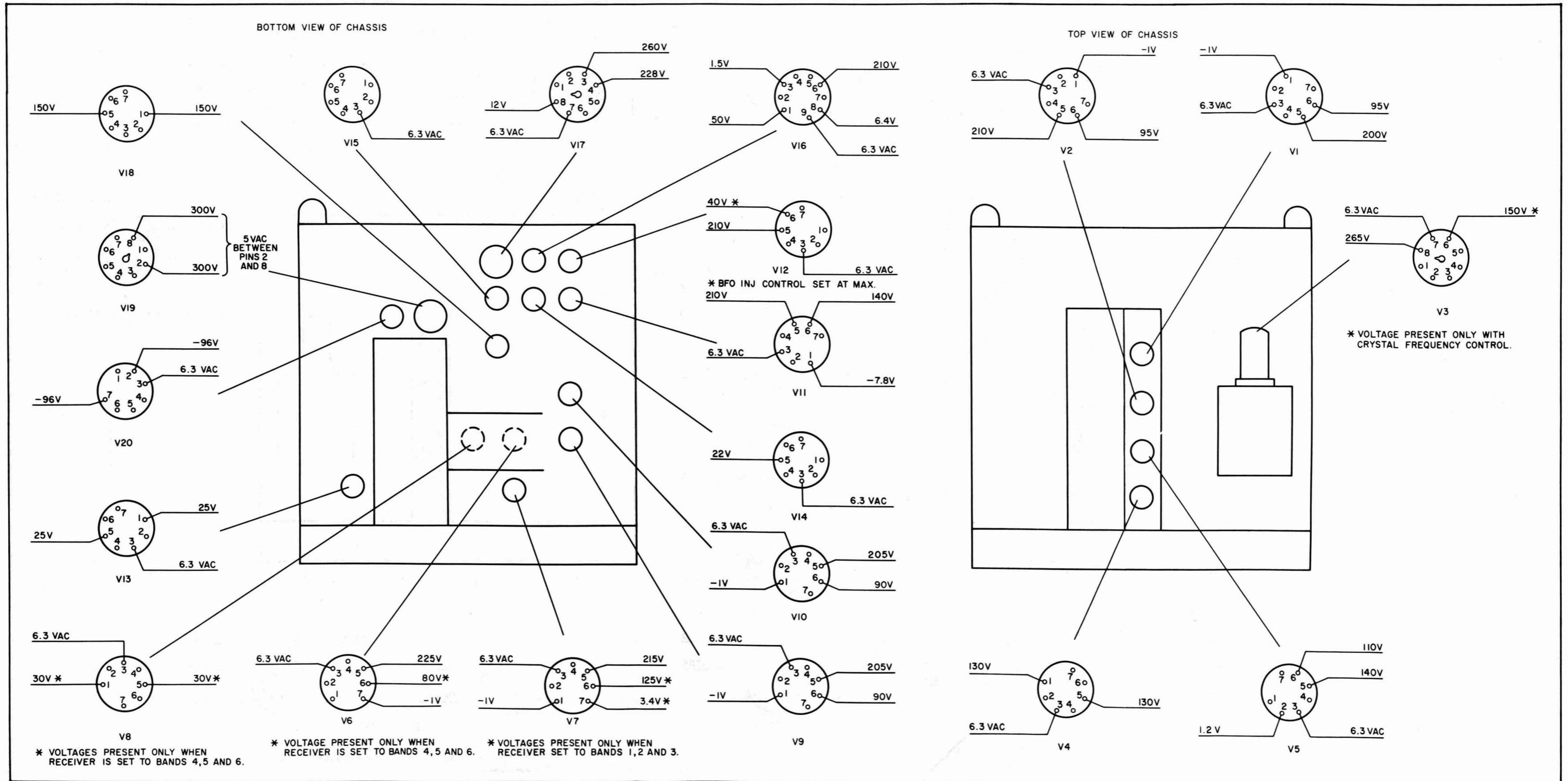

* VOLTAGES PRESENT ONLY WHEN RECEIVER IS SET TO BANDS 4, 5 AND 6.

* VOLTAGE PRESENT ONLY WHEN RECEIVER IS SET TO BANDS 4, 5 AND 6.

* VOLTAGES PRESENT ONLY WHEN RECEIVER SET TO BANDS 1, 2 AND 3.

Figure 7-2. Tube-socket Terminal Voltage Diagram

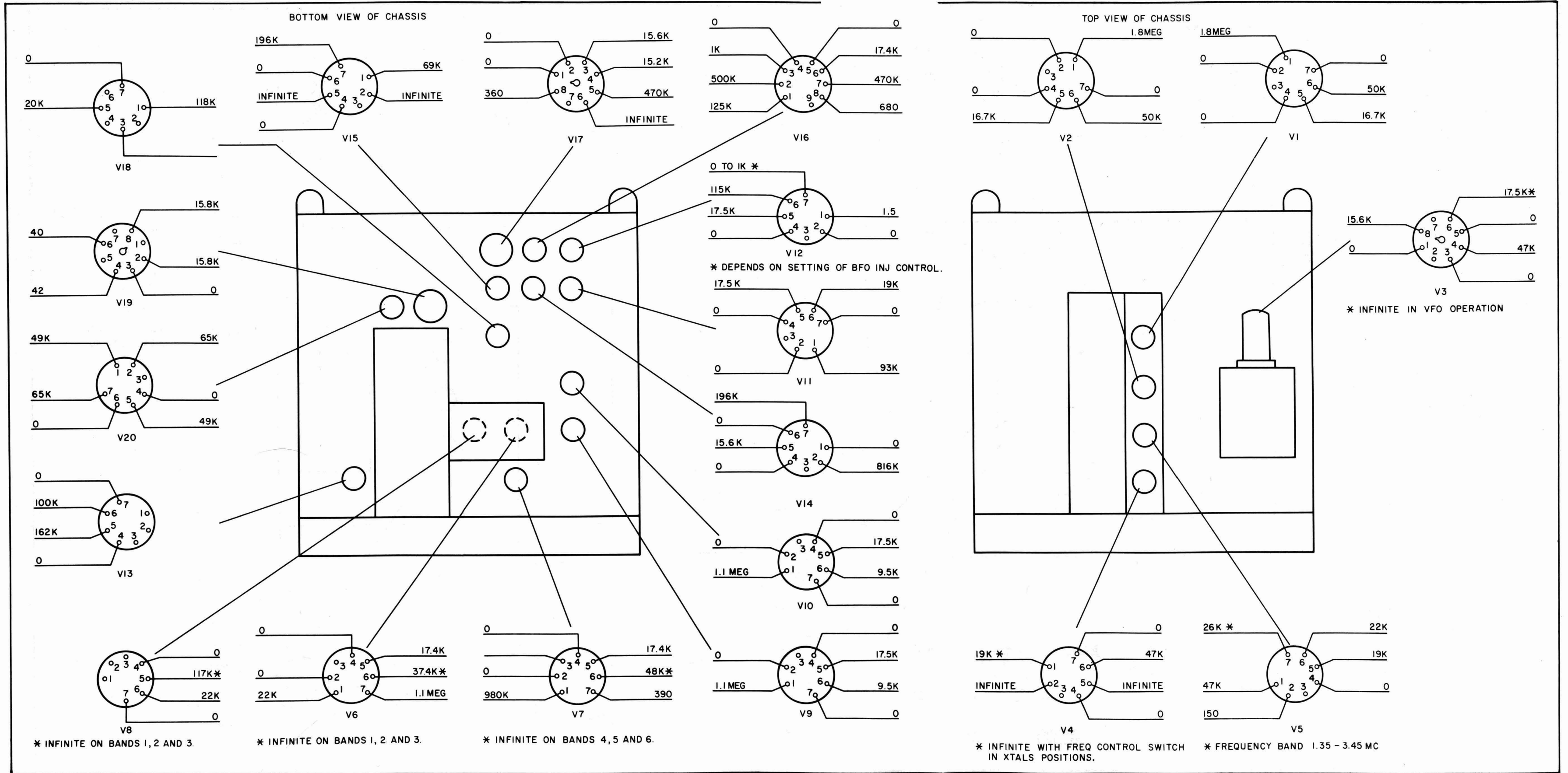

Figure 7-3. Tube-socket Terminal Resistance Diagram

SECTION VIII
DIFFERENCE DATA SHEETS
(NOT APPLICABLE)